

Power System Reliability and Maintenance Evolution

Alvarez-Alvarado, M.S.; Donaldson, D.L.; Recalde, A.A.; Noriega, H.H.; Khan, Z.A.; Velasquez, W.; Rodriguez-Gallegos, C.D.

DOI:

[10.1109/ACCESS.2022.3172697](https://doi.org/10.1109/ACCESS.2022.3172697)

License:

Creative Commons: Attribution (CC BY)

Document Version

Publisher's PDF, also known as Version of record

Citation for published version (Harvard):

Alvarez-Alvarado, MS, Donaldson, DL, Recalde, AA, Noriega, HH, Khan, ZA, Velasquez, W & Rodriguez-Gallegos, CD 2022, 'Power System Reliability and Maintenance Evolution: A Critical Review and Future Perspectives', *IEEE Access*, vol. 10, pp. 51922-51950. <https://doi.org/10.1109/ACCESS.2022.3172697>

[Link to publication on Research at Birmingham portal](#)

General rights

Unless a licence is specified above, all rights (including copyright and moral rights) in this document are retained by the authors and/or the copyright holders. The express permission of the copyright holder must be obtained for any use of this material other than for purposes permitted by law.

- Users may freely distribute the URL that is used to identify this publication.
- Users may download and/or print one copy of the publication from the University of Birmingham research portal for the purpose of private study or non-commercial research.
- User may use extracts from the document in line with the concept of 'fair dealing' under the Copyright, Designs and Patents Act 1988 (?)
- Users may not further distribute the material nor use it for the purposes of commercial gain.

Where a licence is displayed above, please note the terms and conditions of the licence govern your use of this document.

When citing, please reference the published version.

Take down policy

While the University of Birmingham exercises care and attention in making items available there are rare occasions when an item has been uploaded in error or has been deemed to be commercially or otherwise sensitive.

If you believe that this is the case for this document, please contact UBIRA@lists.bham.ac.uk providing details and we will remove access to the work immediately and investigate.

Received February 18, 2022, accepted April 30, 2022, date of publication May 4, 2022, date of current version May 19, 2022.

Digital Object Identifier 10.1109/ACCESS.2022.3172697

Power System Reliability and Maintenance Evolution: A Critical Review and Future Perspectives

MANUEL S. ALVAREZ-ALVARADO¹, (Member, IEEE),
DANIEL L. DONALDSON², (Member, IEEE), ANGEL A. RECALDE¹, (Member, IEEE),
HOLGUER H. NORIEGA¹, (Member, IEEE), ZAFAR A. KHAN³, (Senior Member, IEEE),
WASHINGTON VELASQUEZ¹, (Senior Member, IEEE),
AND CARLOS D. RODRÍGUEZ-GALLEGOS⁴, (Senior Member, IEEE)

¹Faculty of Electrical and Computer Engineering, Escuela Superior Politécnica del Litoral (ESPOL), Guayaquil 090112, Ecuador

²Department of Electronics, Electrical and Systems Engineering, University of Birmingham, Birmingham B15 2TT, U.K.

³Department of Electrical Engineering, Mirpur University of Science and Technology, Mirpur, Azad Jammu and Kashmir 10250, Pakistan

⁴Solar Energy Research Institute of Singapore (SERIS), National University of Singapore (NUS), Singapore 117574

Corresponding author: Manuel S. Alvarez-Alvarado (mansalva@espol.edu.ec)

This work was supported by the Decanato de Investigación from the Escuela Superior Politécnica del Litoral (ESPOL).

ABSTRACT In the last two decades, the number of strategies for planning the maintenance of power systems have increased considerably. As societal dependence on power system infrastructure continues to grow, there is an increased need to identify the best practices in the field of power system maintenance planning to ensure the continued reliable operation of the grid. This paper presents a comprehensive and systematic state-of-the-art review of advances in power system maintenance and the significance for the field of power system reliability. As the main contributions, this paper systematically organizes the published literature, and analyses the most relevant milestones in the context of power systems adequacy and security enhancement, producing a taxonomy of the different maintenance strategies. This includes detailing existing approaches for power system maintenance planning, and providing clear definitions, models, methods, and characteristics of maintenance policy. The review also includes the most relevant standards employed in the power system maintenance field. Finally, areas requiring further research are identified alongside emerging trends in power system maintenance, to inform industry practice and support further research.

INDEX TERMS Adequacy, maintenance, power systems reliability, security.

I. INTRODUCTION

Over the last half-century, power systems have been growing exponentially around the globe, creating a pathway for industrial development [1]. As the grid grows, operators must work to maintain the reliability of the grid as components age. The term ‘reliability’ is defined by the IEEE as “*The probability that a system will perform its intended functions without failure, within design parameters, under specific operating conditions, and for a specific period of time*” [2]. Reliability can be quantified using analytical or probabilistic methods, which are based on the operational records of the power systems components. Then, it is possible to estimate future

failures that can be avoided by taking preventive actions. Another advantage that these methods offer lies in the evaluation of historical component performance and simulation of past behavior. This reliability evaluation can be employed to analyze the operational state of a component in the past or future [3]. An illustration of the reliability evaluation process is given in Figure 1.

In the field of power systems, reliability refers to the capacity to provide continuous service and be able to satisfy electrical demand [4]. The reliability assessment of modern power systems consists of two main categories: adequacy and security. Adequacy refers to the presence of adequate facilities to supply the load demand in a power system when one or several components goes out of service due to sudden failure events. Power system adequacy studies are further divided

The associate editor coordinating the review of this manuscript and approving it for publication was Guangya Yang¹.

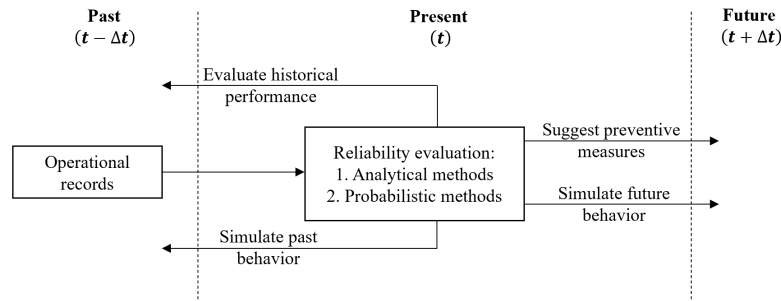

FIGURE 1. Reliability evaluation process based on time t .

TABLE 1. Adequacy Hierarchical Levels.

Level	Power System	Description
I	Generation (HLI)	HLI evaluates the ability to supply the total energy demand by considering only the power sources installed in the power system and assumes that transmission and distribution systems are 100% reliable [6].
II	Generation & Transmission (HLII)	HLII assesses the ability of the generation-transmission system to supply the demand and evaluates the impact of failures on generators, lines, buses, and electrical protections involved in the power systems [7].
III	Generation, Transmission, & Distribution (HLIII)	HLIII encompasses the generation, transmission, and distribution system and evaluates the adequacy of the main load points located in the primary distribution circuits, considering any component failure installed in the power system [8].

TABLE 2. Security Schemes.

Scheme	Division	Description
Static	Voltage Limits (SSV)	Studies the ability of a power system to maintain the buses voltages within the permitted limits (established by standards) at a steady state operation after a disturbance occurs [9].
	Thermal Limits (SST)	Analyses the power capacity that can flow through a transmission line depending on its electrical shunt and series parameters [10].
Dynamic	Voltage Stability (SDV)	Assesses the ability to maintain steady state voltage through active power balance [11].
	Angular Stability (SDS)	Examines the ability of synchronous generators to restore to normal operating conditions after being subjected to a disturbance [12].
	Frequency Stability (SDF)	Explores the ability to balance active power (generation, load) in order to keep the frequency within the permitted limits (established by the standards) [13].
Cyber Security	Hardware-Software (SCS)	Investigates the ability restore after an incident on IT services of the power system occurs. The study concerns hardware and software infrastructures [14].

into three hierarchical levels as described in Table 1. Security refers to the ability of a power system to deal with sudden disturbances; therefore, security measures the capacity of the system to respond when the system operates under static or dynamic instability events or even under cyber-attacks circumstances [5]. Each security scheme is described in Table 2. For a better understanding, Figure 2 gives a pictorial summary of the categorization of power system reliability evaluation.

To enhance system reliability and increase the useful life of industrial equipment, while minimizing cost, maintenance strategies are employed. However, maintenance actions were not always as important as they are in present times since the concept of maintenance has evolved. Figure 3 presents this evolution.

The concept of maintenance first appears during the first industrial revolution (IR) (between 1760-1870), in England [15]. At that time, maintenance was considered as a type of ‘necessary rework’ with low relevance for the industry, and consisted of corrective maintenance (CM) schemes [15].

CM focuses on the identification, isolation, and rectification of a fault so that the failed component can be restored to an operational condition within the tolerances or limits established for in-service operations [16]. CM is carried out after failure detection and is aimed at restoring an asset to a condition in which it can perform its intended function [16]. The main deficiency with CM is that in some circumstances it is preferable to proceed with the refurbishment of the component rather than maintenance. For example, in case of severe damage in the core of a transformer, the cost of CM is close to the cost of a new transformer acquisition [17], therefore CM is not affordable for this particular case.

During the 2nd IR (between 1870-1945), industry grew rapidly due to advances in mechanical and electrical machines [18]. With the higher demand of products,

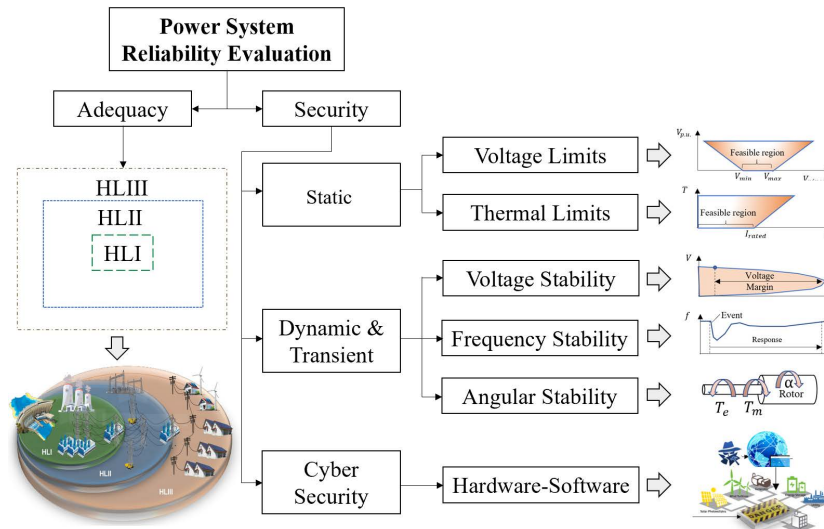

FIGURE 2. Categorization of power system reliability evaluation.

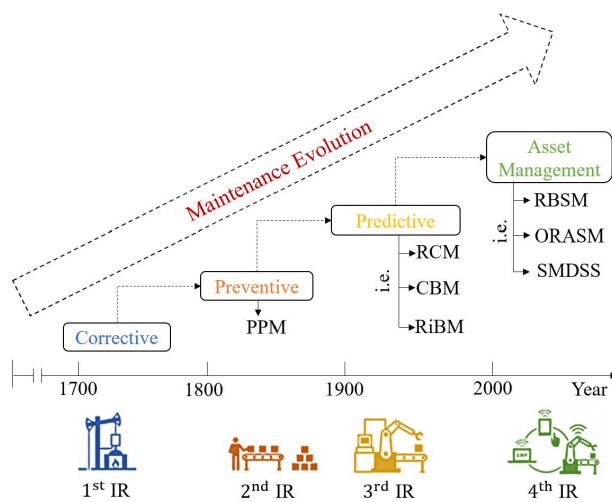

FIGURE 3. Maintenance Evolution.

breakdowns in the industry caused higher expenses, and CM was found to be insufficient. As a result, the need arose for a new scheme, preventive maintenance (PM). PM consists of conducting maintenance at predetermined intervals or according to prescribed criteria, aimed at reducing the failure risk or performance degradation of the equipment [19]. Different from CM, PM proposes maintenance cycles according to the need of the component, leading to concept of periodic preventive maintenance (PPM). Nevertheless, every component operates under different circumstances, and maintenance should be scheduled based on the reliability model of the component [19]. This could potentially bring a higher benefit in comparison with the periodic preventive maintenance (PPM) strategy. In response to this need, during the 3rd IR (between 1945-2010) maintenance evolved from PM to predictive advances.

Predictive maintenance (PdM) formulates a maintenance schedule optimization problem, whose objective is to minimize the occurrence of failures of a component while maximizing profit [20]. Some strategies within PdM include: Reliability-Centered Maintenance (RCM) whose objective is to decrease the maintenance cost, by focusing on the most essential functions of the system, and preventing maintenance actions that are not rigorously required [21], [22]; Condition Based Maintenance (CBM) whose objective is to monitor the health of the component, and based on that it is possible to detect incidents that could arise in the event of failure, and the likelihood of that incident [23]; and Risk-Based Maintenance (RBM) whose goal is to reduce the overall risk of facilities via maintenance.

Even though, PdM promises huge benefits from the reliability point of view, it does not consider the identification of the optimal maintenance strategies for the industry’s auxiliary assets in real time. However, with the 4th IR (also known as industry 4.0) bringing advances in cyber physical systems starting, in 2011, such deficiency was resolved, and the concept of maintenance evolved into a new paradigm termed ‘Asset Management’ (AM) [24].

AM is defined as a comprehensive maintenance strategy that combines risk-controlled optimization and life-cycle management of an asset [25]. It consists in determining the best moment to maintain assets based on the asset operating data obtained using cyber physical systems. Then, the next maintenance period is projected based on past operation. As a result, the amount of unnecessary maintenance is reduced, generating lower outage costs and improving maintenance efficacy [26]. Strategies within AM include use of: smart-inspections [27], smart-devices [28] and smart-services (SS) [29], resulting in the Reliability Based Smart Maintenance (RBSM) model [30]. Some other strategies under the AM scheme are Operational Risk Assessment

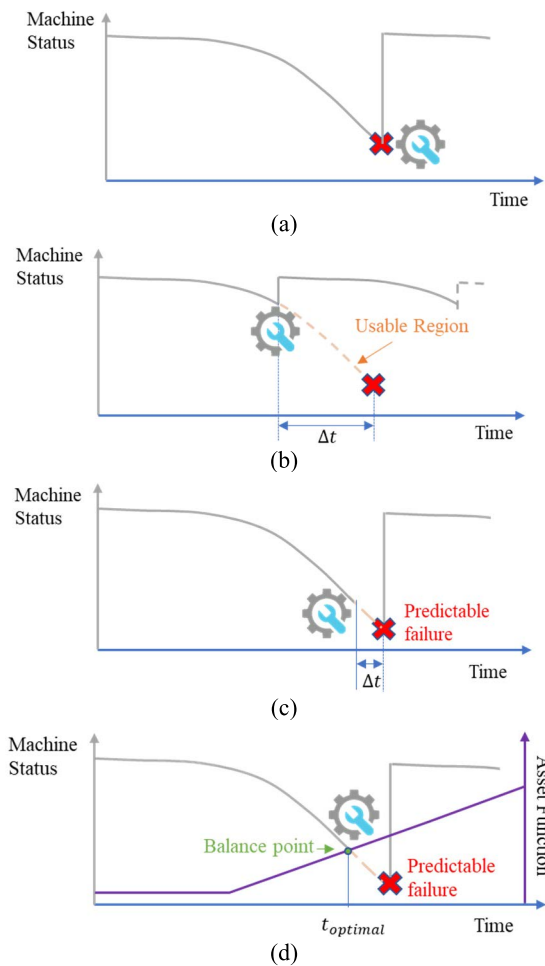

FIGURE 4. Maintenance Function for: (a) CM; (b) PM; (c) PdM; (d) AM.

with Smart Maintenance (ORASM) which identify the best maintenance schedule based on the operation of each asset involved in some process [31]; and Smart Maintenance Decision Support System (SMDSS) that allows physical asset to have a defined maintenance plan which utilizes analytical models to form decision actions [32]. Figure 4 identifies the main features of each of the four maintenance paradigms.

The motivation of this paper rests on the British Standards that define maintenance as: “*The combination of all technical and administrative actions, including supervision actions, intended to retain an item in, or restore it to, a state in which it can perform a required action.*” [33]. This suggests that maintenance protocol involves different actions, and based on this, different maintenance strategies can be performed. However, there is not a singular best strategy for all components. Some strategies may lead to better performance than other depending on the reliability model of the component. Therefore, there is a need to report important findings of the different maintenance strategies with their advantages, limitations, and gaps.

To address this challenge, this paper presents a structured literature review of the state-of-the-art advancements

in maintenance and the contribution of maintenance to the enhancement of power system reliability. The paper also proposes a comprehensive taxonomy of the most relevant maintenance strategies. In addition, the paper provides insight the existing maintenance standards and future perspectives in the field of power system maintenance planning. The structure is as follows: Section 2 presents the methodology followed in this paper; Section 3 provides a topology of the maintenance strategies applied in the power industry with a view to enhance system reliability; Section 4 provides examples of major international power system maintenance standards; Section 5 presents future directions in the field power system reliability and maintenance; and Section 6 presents overall conclusions.

II. METHODOLOGY

The protocol followed to develop this paper starts with the identification of the scientific challenges, followed by the research questions, search strategy and article selection. Each of these are described as follows.

A. REVIEW OBJECTIVES

The primary objectives of this review are to: 1) present a brief epistemology regarding maintenance evolution in the industry; 2) categorize the main studies in the field of power system adequacy and security; 3) propose a taxonomy for maintenance strategies in the context of power system reliability; 4) report the main developed maintenance standards applied to power systems; 5) identify the main challenges and future issues related to maintenance and power system reliability.

B. RESEARCH QUESTIONS

The research main question (MQ) and sub-questions (SQ) that drive the development of this review are presented in Table 3. The goal of MQ formulation is to report the different maintenance strategies and how they are applied in the power industry. SQ1 lists the main means of disseminating research concerning power system maintenance evolution. The SQ2 surveys the most found terms, for the creation of standardization and presentation of the power system maintenance taxonomy proposal. SQ3 identifies and relates the existing power system maintenance standards. SQ4 discusses new paradigms in the field power system maintenance and how they can be applied.

C. SEARCH STRATEGY

The literature review is developed using Google Scholar as starting database since it performs a full-text search in publications' title and body. The main idea is to obtain a higher volume of results, which are subsequently evaluated, leading to the identification of possible challenges related to power system maintenance planning strategies. The search string is adapted and applied to the Google Scholar, IEEE, ScienceDirect, Scopus, and Web of Science search engines, in this hierarchical order.

TABLE 3. Research Questions.

Identifier	Issue
MQ	What are the future trends concerning power system maintenance?
SQ1	What are the main means of disseminating research aligned with power system maintenance evolution?
SQ2	What is the taxonomy of the maintenance planning strategies to enhance power system reliability?
SQ3	What standards guide power system maintenance strategies?

(("power system maintenance strategies" or "power system reliability and maintenance") and ("maintenance for adequacy generation") and ("maintenance for composite power system evaluation" or "transmission adequacy and maintenance" or "distribution adequacy and maintenance") and ("maintenance for power system security") and ("maintenance for power system static security" or "power industry maintenance and voltage limits" or "power industry maintenance and thermal limits") and ("power industry maintenance for power system dynamic security" or "power industry maintenance and voltage stability" or "power industry maintenance and angular stability" or "power industry maintenance and frequency stability") and ("power system maintenance and cyber security") and ("power system maintenance standards"))

FIGURE 5. Search String.

The paper uses a search string that focuses on maintenance strategies to enhance power system reliability. The study considers gaps in the existing literature and future challenges in the described research line. The search string considers some identified characteristics, for example, most of the data of approaches of maintenance strategies are applied in the adequacy and security power systems field. Figure 5 presents the research string employed in this paper.

D. ARTICLE SELECTION

The search string presented in Figure 5 was applied on 10/20/2021 at Google Scholar, with results limited to the twenty-year period from 2001–2021, excluding patents This resulted in approximately 7800 articles, which were then assessed for further screening. The intention of the screening is to evaluate the context of the string and the MQ and SQ’s questions. For the cataloguing, some manuscripts are excluded based on the criteria listed in Table 4. The breadth of manuscripts published in the last 20 years reveal the answer to the question SQ1 — What are the main means of disseminating research aligned with power system maintenance evolution? A more descriptive answer to the question is presented in Figure 6 and Figure 7.

III. MAINTENANCE STRATEGIES IN POWER SYSTEMS

This section answers the question SQ2 — “What is the taxonomy of the maintenance planning strategies to enhance power system reliability?” this section starts with a critical

TABLE 4. Quality Assessment Criteria.

Criterion	Issue
1	Remove all publications outside of the 20-year period from 2001 to 2020.
2	Remove all publications that do not address maintenance applied to power systems, including doctoral thesis.
3	Remove documents published between 2001 and 2017 with less than 20 citations.
4	Remove documents published between 2017 and 2021 with less than three citations are considered.
5	Add a range of standards for review, that have been approved by a major standards body.

analysis of the current research, beginning with corrective and preventative maintenance, moving to predictive maintenance and finally asset management, and ends with the description of the taxonomy of the maintenance planning strategy. Research in each area is grouped according to adequacy and security.

A. CORRECTIVE AND PREVENTIVE MAINTENANCE

At the beginning of the industrial era, CM improved the efficiency of industrial processes as described in Section I. However, CM is no longer widely used, due to its poor economic benefit. In some scenarios, the application of CM may require the same economic investment as replacement of the full system [34]. In order to address this deficiency, various models have been evaluated to represent failure mechanisms that integrate PM protocols [35].

The breadth of manuscripts published in the last 20 years reveal the application of CM and PM with different strategies. Markov chain and Monte Carlo Simulation using an Exponential distribution function are the most common strategies used to assess adequacy. This is attributed to their ability to simply capture the behavior of the components failure rate during the useful life [36]. Applications at HLI in different generation units can be found in [6], [37]–[39], while at HLI the applications extend to switching stations [40]. To capture the wear-out stage of the component some authors consider Weibull distribution as presented in [41]. Literature also depicts application of static and dynamic security voltage using the same described strategies applied to power transformers and circuit breakers in [42].

At the dynamic security field, the most basic maintenance strategy applied is an inspection test (i.e. [43], [44]). This consists of a visual routine to determine the status of the component following the standards established by the manufacturer. The objective is to present, as far as possible, continuous surveillance of the component. In the area of reliability modelling, literature reports the employment of different distribution functions depending on the power system equipment. For instance, authors in [45] and [46] for nuclear and thermal power plant propose the use of exponential distribution, respectively; in [47] Poisson distribution is employed

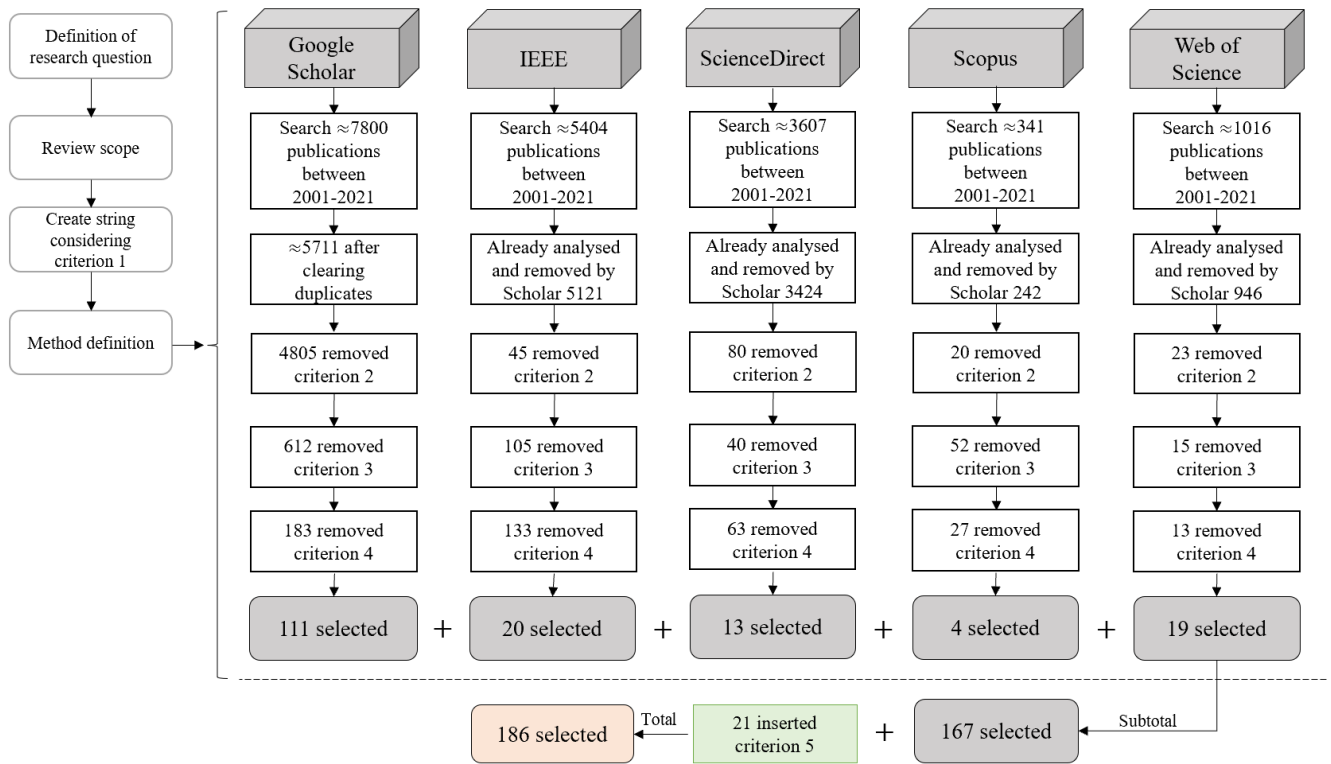

FIGURE 6. Screening of research.

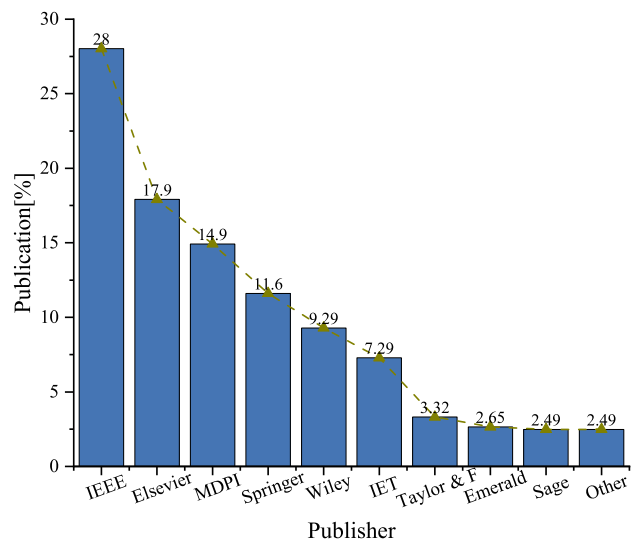

FIGURE 7. Distribution of publications by Publisher (answer to SQ1).

for power transformer, while in [48] uses Weibull distribution for general power system equipment. This is attributed to the fact that every power system component presents a different historical data, so it is expected to present different statistical metrics. A summary of the described CM and PM strategies divided by reliability fields is presented in Table 5.

A milestone in the reliability modelling field is the Kijima model due to its ability to capture the lifetime cycle of

the components. The guidelines used are specified by the part’s age interval standards. In [49], the Kijima model is used to estimate the maximum likelihood and develop a mathematical model for the reliability and maintainability of the system simultaneously. Subsequently, the rejuvenation of dynamical systems by considering CM and PM in two different levels: perfect and imperfect is modeled. The levels assess the degree of maintenance (effort during maintenance) that have been employed during maintenance actions, i.e., for a perfect maintenance the degree takes a value of one, otherwise (imperfect maintenance) it takes a value greater or equal to zero and lower than one. Similar studies apply the Kijima model on different power systems components, such as power generators [50], and transformers [51], which validates its effectiveness on power system reliability assessment. Therefore, Kijima model can provide a beneficial means for power system owners to enhance maintenance.

In general, CM and PM reduce the probability of shut-downs operations due to unexpected failure, leading to economic benefits. Nevertheless, due to the nature of these schemes, the minimization of cost cannot be assured. Moreover, CM strategies should only be employed in non-critical areas where the consequences of component failure are minor, there are no immediate safety hazards, investments are small, and failure recognition and repair are rapid and feasible. On the other hand, while the goal of PM is more comprehensive, sometimes it is not simple to implement due to variables required for analysis including the equipment

TABLE 5. Existing CM and PM strategies grouped by reliability fields.

Reliability Field	System or component	Strategy	Reference
HLI	Unit generation of the RTS and RBTS test systems	Markov Chain based on Exponential Distribution combined with Monte Carlo Simulation	[37]
	Unit generation of the RBTS test system	Markov Chain based on Exponential Distribution combined with Monte Carlo Simulation	[38]
	Wind turbine	Markov Chain based on Exponential Distribution combined with Monte Carlo Simulation	[39]
HLII	Switching station	Markov Chain-Based Exponential Distribution	[40]
	Air-blast circuit-breaker	Markov Chain-Based Weibull Distribution	[41]
SSV & SDV	Power transformer and circuit breaker	Markov Chain based on Exponential Distribution Monte Carlo Simulation	[42]
SD {A, F}	Automatic bus transfer switches	Inspection Test	[43]
SDV	Shielded power cable	Inspection Test	[44]
Modelling	Valves of Olkiluoto nuclear power plant	Markov Chain based on Exponential Distribution	[45]
	Thermal power plant in Nigeria	Probabilistic Model based on Exponential Distribution	[46]
	Power Transformers in Adiyaman District	Probabilistic Model based on Poisson Distribution	[47]
	Power equipment in general	Probabilistic Model based on Weibull Distribution	[48]
	General power system component	Kijima model	[49]
	Power generators	Kijima model	[50]
	Power transformers	Kijima model	[51]
SD {V, A, F}	Piping system for a gas and steam turbine in Chania, Greece	Fuzzy Knowledge for Condition Based Maintenance	[88]
Optimal maintenance policy	Electrical machines	Probabilistic Model based on Exponential Distribution	[89]
	Power transformer	Probabilistic Model based on Weibull Distribution	[90]
	HVDC in electric aircraft	Fault Tree Network Diagram	[91]
	Electrical vehicles charging station	Fault Tree Network Diagram	[92]
	Static Var Compensator	Fault Tree Network Diagram	[93]
	Protective relays in polluted power systems	Markov chain for Reliability Centered Maintenance	[98]
	Power generator	Continuous-time Markov Chain for Reliability Centered Maintenance	[99]
	Power generator	Semi-Markov Decision Processes for Reliability Centered Maintenance	[100]
	Transmission network	Statistical Model Based for Reliability Centered Maintenance	[94]
	Distribution System (Algeria)	Exponential distribution for Reliability Centered Maintenance	[95]
	DC power electronic-based power system	Weibull Distribution for Reliability Centered Maintenance	[96]
	Load sharing system	Probabilistic Model based on Poisson and Normal Reliability Centered Maintenance	[97]
	Railway power supply system	Sequential Quadratic Programming with Genetic Algorithm for Risk-Centered Maintenance	[101]
	Power plant	Multi-Objective Genetic Algorithm for Risk-Centered Maintenance	[102]
	Gas turbine (Siemens SGT600)	Binary Genetic Algorithm for Risk-Centered Maintenance	[103]
	Substation	Non-dominated Sorting Genetic Algorithm for Risk-Centered Maintenance	[104]
	Nuclear power plant	Genetic Algorithm for Risk-Centered Maintenance	[105]
Power generator	Genetic Algorithm and Simulated Annealing for Risk-Centered Maintenance	[106]	
Power transformer	Fuzzy logic with Condition Monitoring and Risk Centered Maintenance	[107]	

structure, environment complexity, ambiguous failure mechanisms, and others [20].

B. PREDICTIVE MAINTENANCE

Predictive maintenance (PdM) was developed to address some of the shortcomings of PM. PdM is a scheme that focuses on maximizing profit, while reducing the incidence of failures of a component [52]. The goals of this scheme are formulated as an optimization problem, which aims to increase the reliability, availability, and cost-benefit of equipment or processes by reducing events of failures.

In the area of the power system adequacy, several studies have been developed to explore PdM. The first strategy is based on sampling optimization that incorporates Monte Carlo and Markov Chain and distribution functions with different distribution functions such as Gamma (i.e., [53]) or Weibull [54]. The sampling is used to formulate different scenarios and evaluate the most probable to determine the maintenance cost. In some scenarios where the power system presents several components, the computational burden may be critical. Under this need, authors in [55], [56], and [57] use Integer Linear programming to assess generation adequacy in Taiwan, Trinidad-Tobago, and Kuwait, respectively. This is expanded to use mixed integer linear programming in [58], and validated using the IEEE RTS 24-bus system. Moreover, to reduce simulation time, authors in [59] employed dynamic programming that consists of dividing optimal maintenance planning into several sub-problems with different objective functions. Adequacy at HLI is assessed by authors in [60] using Genetic Algorithms. Several CM and PM procedures are examined, such as, the replacement, minimal repair of failed components, and corrective or preventive replacement of surviving parts. Even though the authors in this study investigate a selective maintenance optimization problem for a multi-state system with stochastically dependent components in a general way, the approach can be extended to power systems. The selective maintenance is presented as a bi-objective optimization problem that considers the expected value and variance of the system reliability, as objective functions, while the constraints are related to the around of time and budget for finding the optimal maintenance planning. The study evaluates an instructive case study, in which the operational states of the component and maintenance performance are considered. The results validate the effectiveness of the proposed approach, showing benefits of considering system interaction between components and the stochastic imperfect maintenance actions. Other metaheuristic optimization techniques employed to enhance system adequacy at HLI can be found in [61]–[63]. In order to offer much more flexibility in adding detailed constraints to the model and reduce the computational burden, literature reports a combination of metaheuristics, such as Genetic Algorithm combined with Simulated Annealing [64], Particle Swarm Optimization combined with Genetic Algorithms [65], and Particle Swarm Optimization combined with Fuzzy C-means clustering technique [66]. Meanwhile,

there are other papers which presents HLI combined with security schemes, e.g., HLI & SS {V, T} as the ones given in [67] that employ a Differential Evolution (DE) algorithm for hydro-power generation along with an approach presented in [68] that uses the Primal–Dual Theorem for single-level mixed integer non-linear optimization applied to power generation.

At adequacy HLII, literature presents some advancements. In [69], maintenance planning is developed using Hill-Climbing with Evolutionary Programming applied to IEEE 30-bus system with six generating units and 41 transmission lines. In this investigation two interrelated maintenance scheduling subproblems are solved, getting in this way the near-optimal solution of the combinatorial problems. The results show improvement over the results obtained by a complementary decision variable method. Another example at this level is found in [70] in which a method called as the Maintenance Coordination Technique (MCT) is tested to manage combined system maintenance scheduling in a deregulated utility system. The results indicate that there are different critical loads, which result in different opportunities for the maintenance planning. Nevertheless, authors conclude that a more critical aspect is clearly defining the risk-criterion for load points. Therefore, while a scheduled maintenance plan may be adequate to address risk from a system perspective, it may inadequately address load point risk. A further case is presented in [71], which studies many characteristics of smart grid monitoring that are used for trade-off studies. The approach is used in an optimization context to ultimately define the optimal group of monitoring points under cost restrictions. The authors employ the failure rates in a Markov Chain to quantify the impact of the monitoring on system reliability. The results state that the smart monitoring of the grid leads enhanced reliability. A more comprehensive study is given in [72] that uses a 51 bus transmission system in Tehran, Iran as a case study. A more comprehensive study is given in [72] that uses as case study a 51 buses transmission system in Tehran, Iran. The authors investigate supply chain networks for adequacy at HLII considering SSV and SST is developed. A drawback of the study is that supply chain network policies are not considered. However, one of the findings of the publication, is the conclusion. This states that the identification of critical points in the system is relevant to secure system reliability, opening a pathway to the development of new policies.

The review continues with the investigations presented at HLIII. In this context, [73] formulates a multi-objective optimization problem that combines CM and PM to enhance the reliability of an urban distribution system in Stockholm, Sweden. In this study, the authors propose three different PM alternatives for each component in the network: 1) keep current the PM level with a constant average failure rate and no change in the PM cost; 2) Improve the PM by considering average failure to be halved with additional cost; 3) decrease the PM assuming the average failure rate value to be doubled with cost savings. Therefore, the optimization

problem consists of determining the optimal PM alternative combination applied to the different components in the system result in the highest saving and system reliability. The optimization problem is solved using an evolutionary particle swarm optimization (EPSO) algorithm. The results are validated by comparing the results obtained using EPSO with the ones using an approximate gradient evaluation bi-criteria optimization method. The authors conclude that it is relevant to introduce more maintenance policies for every component in the system that enables the adequate selection of maintenance level. Another case study is presented in [74] in which a Statistical Model Based on Reliability Centered Maintenance on 11 kV cables is applied. The technique determines the components with significant influence on system reliability and finding causes of failures on such components. Moreover, the results suggest the implementation of monitoring devices to enhance system reliability. Another example is explained in [75], where the Belgian power system is studied using the Petri Net strategy combined with Monte Carlo Simulation. The authors conduct a single constituent analysis with two failure modes, which are based on the degradation level. The objective is to build a decision-aiding instrument for maintenance progress and define costs based on maintenance rules. As a result, an effective maintenance planning to enhance adequacy at HLIII is derived. Another distribution system is analyzed in [76], for which the maintenance scheduling is obtained using Linear Programming and Fuzzy Sets theory through a two-stage analysis. Initially, the approach is focused on a typical primary distribution feeder considering a constant failure rate. Then, the approach is extended to other components of the system, resulting in a comprehensive optimization scenario with many equipment condition constraints. The outcomes in the paper reveal that the proposed approach enables a stronger result than the traditional methods. Following the review, authors in [77] proposed the use of Risk-Based maintenance for optimum extended term maintenance schedule of the distribution system. For this purpose, authors implemented decoupled risk factors to define a maintenance plan with reduced costs. Another advanced methodology to enhance adequacy at HLIII is the Fault-Tree Analysis. In [78], the advantages of Fault-Tree Analysis applied to maintenance planning adequacy in railway power supply in China are exposed. Consequently, a binary decision diagram is introduced to compute the lowest cut sets and their impacts on the global system reliability. The end result is a reliability model that integrates the impacts of maintenance activities are used to evaluate the enhancement of system reliability with regular intervals. Another important advanced strategy implemented in this field is called the Upper and Lower bounds. Authors in [79] apply such strategy over many Feeders in the distribution system of Iran. The maintenance planning is formulated as an optimization problem, which is solved using polynomial upper and lower bounds heuristic algorithms. To validate the efficacy of the approach, the results are compared with the ones using General Algebraic Modelling System's (GAM). The authors conclude that the

proposed approach allows a reduction of load curtailment that enhances system reliability.

Concerning power system security, literature reports PM applications on several Flexible Alternating Current Transmission System (FACTS) devices since they provide solutions to support the utility industry in dealing with fluctuations in power delivery. Authors in [80] support this fact and state that periodic preventive maintenance (PPM) is a substantial protocol to guarantee the reliable operation of the modular multilevel converter (MMC). The MMC is particularly applicable to a wide range of medium and high-voltage power conversion systems, such as high-voltage direct current (HVDC) transmission systems, medium voltage motor drives, renewable energy systems, and battery energy storage systems (BESS). Therefore, implications of PM on this device lead to a better voltage stability, which potentially enhance power system security. The importance of maintenance in power system security is also supported by authors in [81], in which a two-step optimization model for microgrid (MG) planning and scheduling using compressed air energy storage (CAES) and preventive maintenance (PM) is suggested. Firstly, a two-objective planning model is presented, which includes power losses reduction and voltage limits to verify the optimal location and size of multiple generation. Next, a stochastic scheduling model is introduced to balance outputs of distributed generations, charging, and discharging power of CAES, power exchange costs of generation and PM costs of distributed generation. Such actions eventually enhance static security of power systems (voltage limits and voltage stability). A popular strategy to assess power system security is Inspection Test based on Condition Monitoring, which is also known as Condition Based Maintenance (CBM). This strategy consists of monitoring a component's current condition based on physical metrics (i.e., temperature, pressure, etc.). If the metrics go out of the established limits given by the manufacturer, then maintenance actions take place. As a result, CBM offers a: 1. Reduced planned and unplanned downtime since it is performed while the asset is operating; 2. Minimized overtime costs by scheduling the activities; 3. Optimized maintenance intervals. Some relevant work that validates CBM in the power system security field can be found in [82]–[88].

The main goal of PdM is to maximize system reliability. For this purpose, several optimal maintenance policies in the power system field have been developed. Some of them are based on probabilistic models, which employ distribution functions to describe the reliability of every component. The maintenance schedule that maximizes system reliability is obtained by solving the mathematical formulations (i.e., applying derivative criterion to get the maximum or minimum). For instance, authors in [89] proposed the use of Exponential distribution to model the reliability of electrical machines. As a contribution the authors report that machines with maintenance-reliability coupling have breakdown rate inversely proportionality to its PM rate. In fact, the efficiency of the machine with exponential and deterministic PM stays

equal. In addition, the production rate is evaluated in serial lines with a PM-optimized machine, resulting in an improvement of up to 40%. The authors recommend performing PM, if only if, the downtime ratio and the breakdown sensitivity rate to PM are higher than one. Another example is presented in [90] which investigate maintenance impact reliability for power transformers through the use of probabilistic model based on Weibull Distribution. The proposed approach enables to calculate the optimal combination of maintenance activities, providing minimum cost during the planned exploitation period of power transformers.

Fault Tree Network Diagram (also known as Fault Tree Event) is a popular strategy used for PdM. This is a systematic approach that analyses the cascade events produced by a failure of multiple components. Fault tree analysis, combined with the technical expertise from the maintenance staff, leads to insights about the occurrence of failure. Fault tree analysis, combined with the technical expertise from the maintenance staff, leads to a concrete plan of action. Due to its simplicity, such strategy has been used to enhance system reliability in HVDC in electric aircraft [91], electrical vehicle charging stations [92], and static var compensators [93]. The main deficiency with the Fault Network Diagram is that it is not able to reflect derated states of a component (i.e., a failure event that drive a generator to operate with a certain percentage of its capacity).

PdM presents an approach that analyzes breakdowns of a certain component that compromise system functionality known as Reliability Centered Maintenance (RCM). In contrast with PM, RCM is more insightful because the maintenance program is based on the actual status of the most critical elements of a system. Moreover, RCM considers different maintenance policies, such as age replacement policy, block replacement policy and minimal repair policy [94]. For this purpose, RCM utilizes the historical operational of the component records to make decisions concerning maintenance actions. Some approaches to reflect the component behavior include Exponential distribution for distribution system [95], Weibull distribution for power electronics [96], and Poisson process with Normal distribution applied to load sharing system [97]. With a view to increase system reliability with derated states, some authors proposed RCM with Markov chain [98]–[100].

Another approach that belongs to the PdM scheme is Risk-based maintenance (RiBM), which prioritizes assets according to the probability of failure and the consequences of failure. The objective is to minimize the risk aligned with any resources within a system. Lower-risk assets offer more flexible plans that adapt depending on the need. Even though RiBM and RCM are somewhat related, they are not the same. RiBM focuses on risk while RCM prioritizes functionality. Even though “risk” and “productivity” can overlap, they are not the same. The reduction of risk enhances reliability, but the reverse is not true. An asset’s output might improve without eliminating potential hazards. Another difference is that RCM starts from a smaller inventory and focuses on assets

whose function is vital. In contrast, RiBM evaluates all the assets, and then decides which ones take priority. Therefore, the implementation of RiBM is more comprehensive than RCM and the use of advanced optimization techniques are required. In the power system reliability field, optimizations techniques are employed to model RiBM such as dynamic programming [101], Genetic Algorithm [102]–[106], particle swarm optimization, and fuzzy logic [107].

Due to magnitude of the papers analyzed, a summary of the existing PdM strategies sorted by reliability fields is presented in Table 6.

PdM strategies open a pathway for system reliability enhancement in the security and adequacy field. Moreover, they enable maximum operability by organizing maintenance plans and spare parts inventories based on component health metrics. However, with advancements in information and communication technologies, real-time measures can be obtained, leading to a new paradigm called asset management, which is described in the next section.

C. ASSET MANAGEMENT

AM enables to program a maintenance plan in the optimum time with the precise maintenance effort through different optimization techniques that include linear programming, metaheuristics, and machine learning. The key drivers for AM schemes are the cost function and maintenance coordination among the assets presented in the system. Consequently, unnecessary maintenance actions are avoided, leading to a cost reduction and an increment in of operation efficiency of the system [26]. To achieve this objective, many studies propose different approaches that combine statistics with linear programming and metaheuristics techniques [108]–[139].

In the last decade, many AM strategies have been developed resulting in the potential for substantial benefit to power system infrastructure owners. In [140], many tools and technologies are displayed, such as information and data management, budget/ investment and costs management, reliability, outages and failure detection/analysis, decision making, maintenance and health management, risk management, load forecasting, monitoring, etc. This work represents a milestone in the field of AM due to its comprehensiveness and simplifies the handling of reliability-related risks, boosting the implementation of assets, and reducing the mediation frequency. Subsequently, the use of resources is minimized. Another relevant study is presented in [141], in which the effects of Industry 4.0 combined with AM enhance the life cycle of a complicated structure in Electrical Energy Distribution (EED). The results are analyzed using Advanced Metering Infrastructure (AMI) in EED of the main supply authority in Quebec- Hydro Québec Distribution which includes more than 4 million customers and 680,000 overhead transformers. The authors conclude that the approach enables a dropping of outages by 7% annually and maintenance expenses reduction around 5% per year. Another finding is presented in [142], which includes an asset management model for electric power control centers, under international standards and

TABLE 6. Existing PdM strategies grouped by reliability fields.

Reliability Field	System or component	Strategy	Reference
HLI	Hydro power plant in Norway	Sampling optimization using Monte Carlo, Markov Chain and Gamma Distribution	[53]
	Power generators of the IEEE-24 bus RTS	Sampling optimization using Monte Carlo, Markov Chain, and a Variety of Distribution Functions	[54]
	Six generation units in Taiwan power system	Integer Linear Programming	[55]
	Power Generation in Trinidad and Tobago	Integer Linear Programming	[56]
	Hydro power plant in Kuwait	Integer Linear Programming	[57]
	Power Generators in the RTS	Mixed Integer Linear Programming	[58]
	Power generators	Dynamic Programming	[59]
	General power system components	Genetic Algorithm	[60]
	Power generator	Particle Swarm Optimization	[61]
	Power generator	Ant Lion Optimizer	[63]
	Power generator of the IEEE 30, 9, 21 test systems	Ant Lion Optimizer	[62]
	Unit generation of the Victoria system	Genetic Algorithm combined Simulated Annealing	[64]
	Power generators in a Cuban power system	Particle Swarm Optimization combined with Genetic Algorithms	[65]
	Tidal power plant incorporated to Roy Billinton Test System	Particle Swarm Optimization combined with Fuzzy C-means clustering technique	[66]
	Hydro-power generation	Differential Evolution Algorithm	[67]
	Power generator	Primal–Dual Theorem for single-level mixed integer non-linear optimization	[68]
Hydro-power generation	Differential Evolution Algorithm	[67]	
Power generator	Primal–Dual Theorem for single-level mixed integer non-linear optimization	[68]	
HLII	Generators and transmission lines of the IEEE 30-bus system	Hill-Climbing with Evolutionary Programming	[69]
	Transmission system facilities of the RTS and RBTS	Maintenance Coordination Technique	[70]
	Transformer and circuit breakers	Markov Chain Multiple State for Condition Monitoring	[71]
	Transmission system in Tehran with 51 buses	Supply chain networks	[72]
HLIII	Distribution system in Stockholm, Sweden	Evolutionary Particle Swarm Optimization	[73]
	11 kV conductors	Statistical Model Based on Reliability Centered Maintenance	[74]
	Belgian power system	Petri Nets	[75]
	Primary distribution feeder	Linear Programming and Fuzzy Sets	[76]
	Distribution line	Risk-Based Maintenance	[77]
	Railway power supply	Fault-Tree Analysis	[78]
Feeder in a distribution system in Iran	Upper and lower bounds	[79]	
SSV	Modular multilevel converter	Bathtub Curve Probability Model	[80]
	Compressed air energy storage in microgrid	Stochastic scheduling Conditional Value at Credibility	[81]
	Thermal power plant	Kalman Filter and Petri Nets for Condition Based Maintenance	[85]
SST	Distribution system	Multivariable Parameter Estimation for Condition Based Maintenance	[86]
	Insulated power cables	Probabilistic theory for Condition Based Maintenance	[82]
SS {V, T}	Thermal power plant	Hybrid Petri Net Modelling for Condition Based Maintenance	[87]
SS {V, T} & SDV	Substation	Control theory for Condition Based Maintenance	[83]
SDF	Transmission network	Kalman filter for Condition Based Maintenance	[84]

management indicators based on real-time supervising. The standard used by the previous studies is ISO 55001, where some processes were embraced such as: documentation, change management, monitoring, auditing, and maintenance. The authors also used many indicators which were observed in real time, and the data stored in long-term historical records and allow the system administrator to make decisions in the control center maintenance process based on the condition of the assets.

To assess power system adequacy, it is common to determine reliability indices that measure the reliability of the system. However, with the incorporation of AM the reliability is associated with a cost function. Therefore, there must be a balance between those variables. For this purpose, literature presents the employment of linear programming techniques and metaheuristics. For instance, Mixed-Integer Linear programming has been used to assess adequacy HLI for maintenance planning of seventy-five generation units of the mainland Spain producers [143], ship power system with shaft electric machines [144], offshore wind turbines [145], thermal power plant [146], and nuclear power plant [147]. Advancement in AM with Genetic Algorithm, Particle Swarm Optimization, Ant Colony Optimization, Ant Lion Optimizer combined with a fuzzy decision-making mechanism are presented in [148]–[151], respectively. An Operational Risk Assessment with Smart Maintenance (ORASM) is conducted in [31]. This study is very comprehensive in the sense that proposes a combination of multiple strategies. It starts with Kijima model to quantify the impact of the maintenance over the failure rate of the component. Next, the authors state that more rigorous maintenance implies more expensive investment, therefore, a novel index called ‘maintenance exertion degree’ subject to the maintenance cost is defined and quantified using Fuzzy Logic. Finally, to determine the optimum maintenance schedule that reduces the operation and maintenance costs, an Accelerated Quantum Particle Optimization over many power generators is applied. The efficacy of the proposed approach is validated by performing a comparison between the benefits over 50 years using ORASM, PPM, and RCM, resulting in favor of ORASM. Authors conclude that ORASM superiority results from its consideration of the operation and risk model of each asset of within the system as opposed to PPM and RCM based only on the component reliability model.

Similarly, to adequacy HLI, adequacy HLII is passed through the employment of linear programming [152]–[159] and metaheuristics [160]–[164]. Nevertheless, for adequacy HLIII different approaches are proposed by taking the best of each algorithm. For instance, it is well known that PSO algorithm presents a high convergence but is very volatile to reach local optimum. On the other hand, Tabu search exhibits strong searching ability (locally and globally) with a low simulation speed. By combining PSO and Tabu search authors in [165] propose a novel approach to obtain a maintenance plan for asset at distribution system, resulting beneficial from the point of reliability. Another relevant

strategy is presented in [166] in which a Risk-Based maintenance Lagrange relaxation and enhanced Linear Programming Relaxation (ELPR) is applied to a distribution system. The approach starts with the reliability data collection of every component. Next, several maintenance schedules are defined and for each a reliability-risk evaluation is carry out to compute the risk, cost and maintenance effort. This followed by defining a maintenance scheduling optimization problem, which is solved using ELPR. However, a limitation with ELPR is that leads to integer values that not necessary are the optimum. To tackle this drawback, Lagrange relaxation is employed. The results verify the efficacy of the approach, as it leads to a cost-effective maintenance plan. In [167], an improved power transformer maintenance plan for reliability centered asset management of Turkish National Power Transmission System is investigated. The approach combines Markov chain with RCM process. The maintenance planning starts with the identification of the main system component. Then, a failure mode and effects on such components are analyzed to construct a Markov diagram using reliability and cost data. A reliability assessment is conducted considering different maintenance plan on critical components. If any maintenance plan meets the expected benefit, then the application of such plan is implemented. The results reveal an increment in the availability, reduction in failure frequency and decreased total cost. A similar approach is presented in [167], in which Reliability Centered Asset Management that incorporates a quantitative relationship between maintenance effort distribution system reliability is presented. Although the proposed approach enables to reach cost-effective maintenance with high system reliability, a deficiency of model lies in the substantial input data that may require significant updates. A more comprehensive study in this field is reflected in [168] that combines Depth-First Search and hierarchy concept to develop an AM approach based on the outage rate and the repairable time for a power transmission system. The manuscript contributes with a strategy that enhances the overall system performance, which considers a PM ranking importance for each component of the distribution system. A similar study is presented in [169], [170] that employs Fuzzy Analytical Hierarchal Process over Tehran distribution system with 21 substations and 174 feeders. Meanwhile in [171], the AM is formulated as an optimization problem that is solved using Multi-objective Genetic Algorithm in Reliability-Centered Maintenance. The versatility of this methodology enables the decision maker to reach optimal maintenance schedule for a system composed of several feeders.

The AM applications expand to power system security. In this field control theory strategies and machine learning techniques are widely used to inform maintenance strategies. For instance, authors in [172] focus on frequency security dynamics of a 2684-bus Brazilian Power System using Support Vector Machine Classifiers. In this paper due to the dimensionality of the system, computational burden is the primary challenge. To overcome this challenge, the authors

proved that with the right amount of data, the proposed approach could solve the AM problem within an adequate simulation time. Another application in which SDF is faced is in [173] where a Deep Forest Reinforcement Learning is used over an automatic generation control. The authors state that using such computational technique, higher control performance can be achieved in comparison to conventional control methods. The authors state that using such computational technique the highest control performance in comparison to conventional control. Another informative case in the area of SSV is shown in [174], in which an Emergency Control Algorithm based on Genetic Algorithms is applied over a multi-terminal voltage source converters for a shipboard power systems. The strategy employs the reconfiguration of the system to enhance system security. The results verify the feasibility and effectiveness of the proposed approach. Some strategies simultaneously assess SST and SVT, such as the case study of an electric propulsion ship power systems that deals with AM to maximize energy efficiency [175]. Literature also presents investigations related to the AM that combine static and dynamic security using different strategies, including: Mixed-Integer Linear Programming applied to IEEE 24 bus [176], Pareto Optimality Theory to control STATCOMs [177], Accelerated Quantum Particle Optimization for STATCOMs [178], Monte Carlo and advanced Control Theory for gas turbines [179], PSO applied to PV-diesel-battery system [180], smart monitoring based on life-cycle for pulse width modulation converter [181], and Adaptive Direct Search for a static var compensator [182].

Machine learning techniques have opened a path to develop new AM techniques applied to power system reliability. Such techniques can be classified as: 1. Supervised Learning (SL); 2. Reinforcement Learning (RL); 3. Unsupervised Learning (UL) [183]. SL methods consist in introducing a function that maps the input and output of a certain process. SL algorithms explore the input-output data to develop an empirical function guided by the user. SL improves in performance as more data is incorporated into the system. Some algorithms that belong to this category have been applied to formulates an AM strategy for power systems security, such as decision trees [184]–[186], neural networks [187]–[197], k-nearest neighbor [198], [199], and support vector machines [172], [200]–[208]. Concerning RL, the trained algorithm can reach decisions on its own. For this purpose, the system incorporates an intelligent agent aimed to maximize the cumulative reward of some specific process. The main difference between RL and SL, lies in the ability to be independent in decision making without needing to perform sub-optimal actions. SL focuses more in determining a balance between the exploitation and exploration of the objective function. A list of applications of RL applied to power systems reliability can be found in [209]. Regarding UL, it consists of identifying patterns from untaged data resulting in a set of probabilities densities. UL processes the information and build an internal representation of the expected value. UL differs from SL and RL in the way

information is organized. Since UL involves iterative process, it becomes self-organized with every iteration. Some UL strategies are clustering, principal component analysis (PCA), and hidden Markov models. Among the presented UL strategies, Markov hidden chain is the most popular used to achieve effective AM focused on power systems reliability as evidenced in [210]–[214].

Advancements in AM have also contributed to improve cyber security systems, providing a reliable operation of the power grid. For instance, authors in [215] assess the impact of a sustainable maintenance of substation auto systems (SAS's) on cybersecurity risk. The approach incorporates a probability density function to simulate a successful cyber-attack. Then, its impact is quantified through a modified hypergraph model of the SAS's logical structure. In this way, the hypergraph is able to classify the critical structure that may be affected by the cyber-attacks. Then, AM is implemented for critical structures. Another contribution in this field is presented in [216], in which a physical power plant simulator is used. Many cyber-physical attacks were introduced into the system to analyze its impact. After different test, the authors conclude that from the perspective of information and communication technologies, power plants susceptible to cyber-attacks and AM implementations is vital to secure power systems. In [217], the impact of cyber-attacks are computed to measure system performance. In response, the authors propose AM by optimizing unit commitment generation using Mixed Integer Linear Programing. Authors reports that the effect of cyber-attacks varies depending on the topology of the network, as configurations with redundancies tend to be more robust in this sense. Authors in [218] and [219] point out the relevance of the SCADA in the monitoring of Power System Assets, which facilitates the real-time system observation and operation by system operators; the SCADA uses real-time data from remote terminal units (RTUs) in power plants and substations through the power system. Other relevant maintenance approaches applied to SCADA include distribution function models [220], data mining [221], and Ensemble Learning Algorithm [222]. A complete description of the state-of-the-art in cyber security can be found in [223]–[226].

Unlike PdM, where maintenance only after a decrease in the condition of the equipment has been observed, AM establishes a programmed maintenance long before an anomaly occurs. This is attributed to fact that AM uses advanced algorithms to predict future health condition of the monitored component. For a better view of each AM strategy described in this section, Table 7 presents the existing AM strategies grouped by reliability fields. In addition, Figure 8 shows the relationship between existing maintenance schemes and their applications in the reliability field.

D. MAINTENANCE STRATEGIES TAXONOMY

After critical review of the presented state-of-the-art in previous sections to address SQ2, the different strategies for

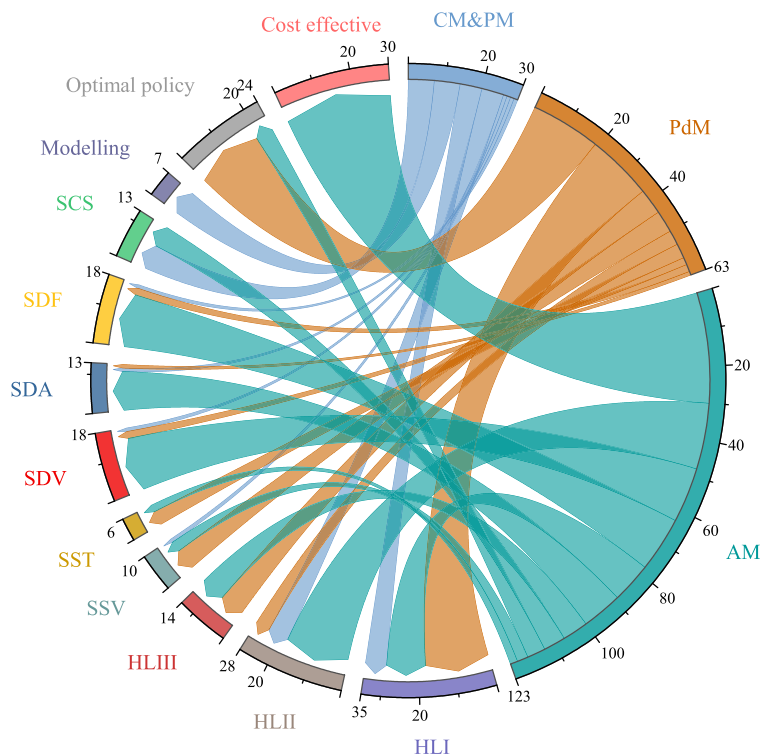

FIGURE 8. Relationship between existing maintenance schemes and applications in the reliability field.

planning maintenance can be categorized into six main groups, which are described as follows.

1) STOCHASTIC-BASED

These strategies consist of defining the best fit probabilistic distribution function (obtained from historical operational records) to capture the reliability of a component. Literature presents the Exponential distribution as the most used to define the failure and repair rates of power components, such as generators, transmission, lines, and transformers. A deficiency of such distribution function is the inability to reflect the aging of the component, leading to inaccuracies on the model [227]. To face this issue, some authors preferred to use Weibull, Poisson, or Pareto distributions. A more accurate model is the Kijima type I and II, as it not only considers the aging, but it also includes the life cycle and maintenance rejuvenation of the component, resulting in a robust strategy for maintenance planning. Following the analysis, most of the investigations combine the distribution functions or even Kijima model with Markov chain to quantify the reliability of the system. This is attributed to the ability of Markov chain to describes a sequence of possible events in which the probability of each event subject to the state accomplished in the previous event. Moreover, due its flexibility, the Markov chain can be employed to compute a Monte Carlo Simulation a determine reliability metrics that define the reliability of a system. Strategies in this group are reported as the first applied to power system reliability assessment, but

present drawbacks regarding the computational burden and the inability to determine optimal planning maintenance.

2) LINEAR PROGRAMMING-BASED

Due to the nature of the maintenance planning, it can be mathematically represented as a linear optimization problem. Moreover, the linear programming can be extended to integer (could be binary) or even continuous, depending on the problem formulation. In scenarios where the maintenance planning is complex (i.e., combination of HLII with SSV and SST) linear programming can be supported by the upper-lower bound or hill-climbing approaches since these approaches lead to better solution convergence by defining an adequate search space. However, the optimal maintenance schedule may not always be linear (i.e., SDF or SDV). Hence, dynamic programming becomes a suitable option, as this strategy divides the problem into different subproblems, leading to minimization in the problem complexity. In general, linear programming offers an excellent accuracy and low time simulation as main advantages. However, its main drawback lies in its problem formulation as for some scenarios the objective function and constraints are not easy to declare. Hence, it is unlikely that the results obtained using linear programming will be optimal.

3) METAHEURISTIC-BASED

Strategies in this group include evolutionary algorithms, swarm intelligence, and physics-based algorithms [228]. The

TABLE 7. Existing AM strategies grouped by reliability fields.

Reliability Field	System or component	Strategy	Reference
Cost effective maintenance	Wind power systems	Condition Monitoring Considering Life Cycle Cost	[108]
	Wind turbine	Stochastic Models with Recursive Technique	[109]
	Distribution feeder	Particle Swarm Optimization	[120]
	High speed-railway	Chaos Self-Adaptive Evolutionary Algorithm	[131]
	Power transformer	Mixed Integer Linear Programming	[134], [135]
	Medium-voltage circuit-breakers and transformers	Time-based Maintenance	[136]
	Circuit Breaker	Condition-Based Monitoring Data	[137]
	Power infrastructure for hurricanes event	Partially Observable Markov Decision Processes	[138]
	Wind turbines	Weibull Distribution Function for Multi-Level Opportunistic Preventive Strategy	[139]
	Wind farms	Sensor-Driven Analytics	[110]
	Offshore wind farms	Nondominated Sorting Genetic Algorithm II	[111]
	Offshore wind farms	Fuzzy Multi-Objective Non-Linear Chance-Constrained Programming	[112]
	Tehran distribution system with 21 substations and 174 feeders	Non-dominated Sorting Genetic Algorithm I	[113]
	Distribution system in Perusahaan Listrik Negara	Health Index and Life Cycle Principles	[114]
	Microgrid system	Karush–Kuhn–Tucker Conditions	[115]
	High-speed electrical trains	Linearization and Simulated annealing	[116]
	Subsea BOP control system	Dynamic Bayesian Networks	[121]
	Wind turbine	Markov Decision Processes	[122]
	Wind power system	Condition Monitoring Systems	[123]
	Railway power system	Weibull distribution with Monte Carlo	[124]
Generator and transmission line (IEEE 118-bus system)	Fuzzy Evolutionary Programming	[126]	
Transformers	Stochastic Models Based on Smart Inspections	[127]	
Cost effective maintenance	Wind turbine	Kijima model Type I and II with optimization technique	[128]
	Offshore wind turbine blades	Probabilistic Model based on Weibull Distribution	[129]
	Overhead line feeders (Dehloran system)	Risk-based maintenance using Outage Time Generation Algorithm	[130]
	Battery Energy Storage Systems	Reinforcement learning-based PM for Smart Maintenance	[133]
	Power transformers	Artificial neural network	[188]
	Battery Energy Storage Systems	Monte Carlo tree search and Deep Neural Network	[190]
	Power generator	Fuzzy Bayesian Artificial Neural Network	[191]
	Offshore wind turbines	Support Vector Machine for Condition based Maintenance	[206]
HLI	Power generators in mainland Spain	Mixed-Integer Linear Programming	[143]
	Offshore wind power system	Mixed Integer Programming	[145]
	Thermal power plant	Mixed Integer Linear Programming	[146]
	Wind, hydroelectric, thermal, and nuclear power plants	Mixed Integer Linear Programming	[147]
	Ship power system with shaft electric machines	Dynamic Programming	[144]
	Power generator	Ant Colony Optimization	[148]
	High pressure injection system of nuclear power plant	Genetic Algorithm	[149]
	High pressure injection system of nuclear power plant	Particle Swarm Optimization	[150]

TABLE 7. (Continued.) Existing AM strategies grouped by reliability fields.

	Power generator	Ant Lion Optimizer in combination with a fuzzy decision-making mechanism	[151]
	Power generators IEEE RBTS and RTS	Kijima Model, Fuzzy Logic, and Accelerated Quantum Particle Optimization for Operational Risk Assessment with Smart Maintenance	[31]
	Transmission system with 3 buses	Support Vector Machine and Random Forest	[207]
HLII	Power generator in IEEE-118 bus system	Sensor-Driven Condition-Based Maintenance with a Two-Stage Mixed Integer Programming	[152], [153]
	Power generator	Stochastic Mixed Integer Linear Programming	[154]
	Power generator	Stochastic Mixed Integer Linear Program	[155]
	Power generators IEEE-RTS	Linear programming	[156]
	Transmission line	Lagrange Relaxation for Linear Programing	[157]
	Power generator and Transmission lines	Lagrangian relaxation and Monte Carlo for Linear programing	[158]
	36 generators	Ant Colony Optimization and Simulated Annealing	[160]
	IEEE 30-bus system	Genetic algorithm multi-objective bilevel optimization	[161]
	Power generator ESKOM	Exchange Market Algorithm	[162]
	32 generating units	Genetic Algorithm	[163]
	Circuit breakers	Nondominated Sorting Genetic Algorithm II	[164]
	Generators, transformers, and transmission lines	Ant Colony Optimization	[117]
	IEEE 6-bus system	Markov Decision Process with Backward Induction Algorithm	[159]
	STATCOM IEEE RTS 24 buses	Markov chain and Accelerated Quantum Particle Optimization	[178]
Combined heat power plant	Neural Network and Genetic Algorithm	[187]	
HLII	IEEE24-RTS	Support Vector Machine and Non-sequential Monte Carlo	[208]
	Power generators in the IEEE 24-bus RTS	Game Theory in Reliability Centered Maintenance	[189]
	Power generators IEEE 39 and 118 systems	Data driven for decision-dependent uncertainty	[186]
HLIII	Transformers	Reliability Centered Asset Maintenance based on Markov Chain	[167]
	Cable components in a rural and urban distribution systems	Reliability Centered Asset Maintenance	[118]
	Distribution System	Risk-Based Lagrange Relaxation and Enhanced Linear Programming Relaxation	[166]
	Transformer and lines	Particle Swarm Optimization and Tabu Search	[165]
	Distribution system: circuit breaker, buses, and lines	Depth-First Search by hierarchy	[168]
	Tehran distribution system with 21 substations and 174 feeders	Fuzzy Analytical Hierarchal Process	[169], [170]
Distribution system with 3 feeders and 71 sections	Multi-objective Genetic Algorithm in Reliability-Centered Maintenance	[171]	
SSV	Multi-terminal VSC-based shipboard power systems	Centralized Emergency Control Algorithm based on Genetic Algorithm	[174]
SS {V, T}	North China-Central China -East China synchronous power grid and Eastern Interconnection USA	Support Vector Machine using Big Data	[200]
	Provincial power grid in China	Support Vector Machine	[201]
	The New England Test System and the New York Power System	Confident Support Vector Machine Ensemble classifier	[202]
SS {V, T}, SDF	Electric propulsion ship power systems	Transfer Function Modelling for Frequency Control	[175]

TABLE 7. (Continued.) Existing AM strategies grouped by reliability fields.

SDV	A 39-bus test case power grid	Multi-objective Biogeography-based Optimization using Support Vector Machine	[203]
	IEEE RTS 96 bus	Support Vector Machine	[204]
	IEEE 14-bus system	Neural Network	[193]
	New England 39-bus test system	Support Vector Machine for Condition based Maintenance	[205]
SDF	New England 39-bus and NPCC 140-bus systems	Neural Network	[194]
	Transmission System	Actor-critic Neural Network	[195]
	Hybrid energy storage system	Neural Network	[197]
	Transmission System in Brazil	Support Vector Machine Classifiers	[172]
	Automatic Generation Control	Deep Forest Reinforcement Learning	[173]
SD {V, A}	IEEE 24-bus RTS	Mixed-Integer Linear Programming	[176]
SD {V, A, F}	STATCOMs	Pareto Optimality Theory	[177]
	Gas turbines	Condition-based Maintenance using Monte Carlo combined with transfer functions	[179]
	PV-Diesel-Battery	Particle Swarm Optimization	[180]
	Pulse width modulation converter	Smart monitoring based on life cycle	[181]
	Static var compensators	Adaptive direct search	[182]
	Western Danish power system with approximately 400 buses	Decision trees	[184]
	Transmission system	k-Nearest Neighbor	[198]
	IEEE 39 bus	Naïve Bayesian, K-Nearest Neighbors, Decision Tree and Ensembles classifiers	[199]
	IEEE 39-bus test case system and part of Iran power grid 66 buses	Decision trees	[185]
	Wind farm	Supervised Learning	[119]
Optimal maintenance policy	Electric vehicles	Hidden Markov Models for Condition Based Maintenance	[210]
	Transformer	Hidden Markov Models for Condition Based Maintenance	[211]
	Gas turbine	Hidden Markov Models for Condition Based Maintenance	[212]
	Wind farm	Hidden Markov Models for Condition Based Maintenance	[213]
	Electrical rotatory machines	Hidden Markov Models for Condition Based Maintenance	[214]
SCS	Power cyber-physical systems in the IEEE 14-bus system	Statistics with Hypergraph	[215]
	ICT of a power plant of combined cycle 380 MW	Real time data acquisition	[216]
	IEEE RTS 96.	Mixed Integer Linear Programming	[217]
	Transmission system	Exponential distribution function	[220]
	Transmission lines	Data Mining	[221]
	Cyber-physical power systems	Ensemble Learning Algorithm	[222]

theory behind the evolutionary algorithm lies in the evolution in nature. In this field, Genetic Algorithms are the most popular employed for optimal maintenance planning, in which a population (candidate maintenance schedule) evolves (best maintenance planning) by crossover and mutation processes. In this way, the solution to the global optima (e.g., lowest cost) in every generation (iteration) is assured. Concerning swarm intelligence, it incorporates mathematical expressions that characterize the collective motion of a group. The most well-known algorithm in this field is PSO, which starts

setting multiple particles located in random positions (candidate maintenance schedule). Then, the particles move to another position based on the best local and global particle (maintenance planning with the lowest cost) and this process is repeated (iteration) until all the particles converge to best position (best maintenance schedule). Optimizers derived from particle swarm optimization are Ant Colony and Ant Lion Optimizers, which are wide used in literature to determine optimal maintenance scheduling. Regarding the physics-based, it uses mathematical formulation of a certain

physical phenomenon. Most of this formulation interacts with the swarm intelligence algorithm. For instance, authors in [30], [31] formulate an scenario of group of quantum particles trapped in delta potential well. Mathematical formulations to describe such phenomenon derives in an algorithm able to compute the best maintenance planning that maximize power system reliability. Literature reports that physics-based methods are less applied in power system reliability field, which presents opportunities for future research. A point of interest to consider, is that metaheuristic techniques do not necessarily assure global optima solution.

4) CONTROL THEORY-BASED

This group of strategies is often used to address power system security. Maintenance of power control systems (i.e., power system stabilizer, load frequency control, and automatic voltage regulator) is crucial to assure continuous power system operation. For this purpose, the most basic strategy to represent the maintenance impact on the system is by using a transfer function. This facilitates to deal with differential equations that drive the nature of the control system. A challenge with this strategy is that it sometimes requires determination of the proportional constants, which is not a simple task. To address this need, some authors proposed the employment of Kalman Filter (also known as Linear Quadratic Estimation). The algorithm determines the best fit value to unknown variables based on a single measurement. Such strategy enables to calculate the constant that optimize the operation of the system, in such a way that optimum maintenance schedule can be obtained. In addition, another common strategy that is widely abroad apply at power system adequacy and security is the fuzzy logic. The maintenance planning using this strategy is developed by assigning fuzzy membership functions to the different linguistic variables (i.e., availability and maintenance effort) based on the experience of an expert in the topic. As a general view, control strategies present high accuracy, however, they are limited by inherent inference of human thinking that may not necessarily lead to the optimal global.

5) REAL TIME DATA ACQUISITION-BASED

With the advancements of information and communication technologies, the Real Time Data Acquisition-based strategies. This group involves a continuous monitoring of the physical variables that may be used as a metric to determine the status of the component. For instance, if a transformer presents high temperature with no load operation, then PM action is performed. With the concept of smart devices, arises the concept of smart inspections that greatly simplifies the task of recording engineering inspections. As presented in literature, this strategy group is commonly used for AM scheme and is becoming very popular. As main advantages this approach brings: 1. Huge risk reduction for safety critical equipment; 2. Build the foundations for predictive maintenance; 3. Unlock tangible efficiencies and cost savings. As exhibits, the use of smart devices is the key driver in

this strategy. Nonetheless, the investment acquisition of such devices is higher in comparison to other strategy groups, becoming its main drawback.

6) MACHINE LEARNING-BASED

The last group of strategies consists of machine learning algorithms, which use the operational historical records and existing monitoring taken from sensors, PLCs, and SCADA to predict the future status of the system. Such process is known as ‘training’ and enables to detect anomalies and test correlations, while searching for patterns across the various data feeds. Some strategies for the training include, data mining, game theory, neural network, and dynamic Bayesian network. These approaches are commonly used to assess maintenance for Hardware-Software components. For the implementation of this strategy, it is required to manage large amount of data that follows a process of cleaning to avoid impressions. This fact becomes a deficiency since this process exhibits high computational burden. For this reason, authors propose a combination of machine learning with other strategies such as fuzzy logic or even metaheuristics. For a better understanding of the taxonomy of maintenance strategies, Figure 9 is presented.

IV. MAINTENANCE STANDARDS FRAMEWORK

This section intends to answer the question SQ3 —**What standards guide power system maintenance strategies?**

There are many sources of standards around the world that affect power system maintenance. Broadly, the entities that produce such standards can be grouped into international, regional, and national organisations. Three of the most prominent international standard entities affecting power system maintenance include the International Organization for Standardization (ISO) [229], the International Electrotechnical Commission (IEC) [230], and the Institute of Electrical and Electronics Engineers (IEEE) [231]. Examples of regional entities include the North American Electrical Reliability Corporation (NERC) [232] and the European Standardization Organizations (European Committee for Standardization (CEN), the European Committee for Electrotechnical Standardization (CENELEC), the European Telecommunications Standards Institute (ETSI)) [233]. Many countries add an additional layer with national standards such as the American National Standards Institute (ANSI) [234], British Standards Institute (BSI) [235], and Standardization Administration of China (SAC) [236]. A unique aspect of the European Standards Organizations is that “*after the publication of a European Standard, each national standards body or committee is obliged to withdraw any national standard which conflicts with the new European Standard. Hence, one European Standard becomes the national standard in all the 34 Member countries of CEN and/or CENELEC.*” [237].

The standard ISO 55000:2014 [238] presents a conceptual overview and terminology for asset management and its adoption in any industry or organization that requires an asset management program. It is followed by the ISO



FIGURE 9. Taxonomy of maintenance strategies (answer to SQ2).

55001:2014 [239], which specifies all the requirements previous an asset management system implementation, and the ISO 55002:2018 [240] that presents the guidelines for implementing an asset management system in accordance with the requirements of ISO 55001. On the other hand, IEC 60300-1:2014 [241] establishes a framework for dependability management (management of reliability, availability, maintainability, and maintenance support). It considers not only the hardware, software, and human aspects, but also the processes throughout the life cycle, safety, and the environment. The IEC 60706-2:2006 [242] examines the requirements to achieve the required targets in the planning of maintenance. Finally, the IEC 62308:2006 [243] describes reliability assessment methods applicable to mission, safety and business critical, high integrity, and complex systems.

Focusing on the electrical engineering field, ISO, IEC, CENELEC, NIST, ANSI, and IEEE have standards for implementing an asset and maintenance management system. ISO 18129:2015 [244] introduces ways to apply performance monitoring and diagnosis for machine(s) up to a complete industrial installation covering the lifetime cycle. A general standard for the maintenance testing of electrical power equipment and systems is the ANSI/NETA MTS-2019 [245]. This standard incorporates a comprehensive field tests and inspection guide to assess the suitability for uninterrupted service, condition of maintenance, and reliability of electrical power distribution equipment and systems. On the other hand, IEC 61709:2017 [246] gives guidelines on how to use the

failure rate data for reliability prediction of electric components used in equipment.

There is a broad range of assets in the electrical engineering field. Focusing on the power system industry, assets can be classified into three main areas: generation, transmission, and distribution. Further into distribution, there is many applications, e.g., electrified transportation (railway electrification), commercial buildings, residential distribution, industrial systems, research facilities, among the main ones. In this work, electric distribution covers the utility network grid up to the delivery point. This includes overhead lines, power distribution cabling systems, and possibly a step-down voltage transformation stage. In current systems, high penetration of distribution generation is possible, so that there could be generation at the distribution level also.

In wind turbine-based generation systems, ISO provides a two-part standard, the ISO 16079-1:2017 [247] and ISO 16079-2:2020 [248]. In the former, guidelines for choosing condition monitoring methods in wind power plant components are detailed, while the latter specifies the implementation of a condition monitoring system for wind turbines, focusing on the monitoring of the drivetrain (main bearings, gearbox, and mechanical aspects of generator). For hydroelectric generation, the ISO 19283:2020 [249] and IEEE 492:1999 [250] focuses on the monitoring and diagnosis of electrical machines for hydroelectric generating units. The ISO standard aims at improving the reliability of implementing an effective condition monitoring approach by recommending effective techniques to detect

and diagnose machine faults before they happen, which are associated with the most common failure modes. The IEEE standard provides general maintenance recommendations for synchronous hydro-generators and generator/motors (excluding the prime mover).

One of the most important assets for electric utilities and transmission system operators is the power transformer. The IEEE C57.93-2019 [251] covers not only maintenance but also inspection and installation of liquid-immersed transformers rated 501kVA and above at voltages of 1kV and above. Note that special transformers, e.g., transformers for furnaces, rectifiers, etc., are not included in this standard. The ISO 18095:2018 [240] provides guidelines to help in implementing an effective condition monitoring and condition-based programme for single-phase AC power transformers with ratings of 1kVA and above, and three-phase AC power transformers of 5kVA and above. Significant attention has been paid to the health monitoring through oil sampling and testing, noise analysis, partial discharge tests, and thermography. Whenever shutdowns in possible, tan-delta, water content, dynamic resistance, SFRA, and RDC are commonly performed in practice.

IEEE 1808-2011 [252] is a guide for collecting and managing transmission line inspection and maintenance data. It is a reference to assist electric utilities with the development of computer-based tools for enhancing usability of systems. A more 'in-the-field' approach is contained in the IEEE 516-2021 [253] which provides general recommendations for performing maintenance work on energized power lines. It covers certain laboratory testing of tools and equipment, field maintenance, and care of tools and equipment.

With respect to protection systems, NERC PRC-005-6 [254] provides a standard for protection system, automatic reclosing, and sudden pressure relaying maintenance. It can be applied in all areas of transmission, generation, and distribution. With the advancement of information technology system and the increase in data flows, digital relays have accommodated communication functionalities that have also integrated local protection functions with the rest of the substation. That is the case of the IEC 61850 [255] that implements a complex network of very high-speed raw data (usually based on fiber optics) and application networks that are capable of automatic reconfiguration of protection parameters in case the power system topology changes (due to failures, disconnections, etc.). This standard has also been part of a broader initiative in the integration of systems in electric utilities.

Since the first installations of power systems almost a century ago, the electric utility business has radically changed due to the introduction of information technology systems, remote control, telemetry, and the interconnection of power systems. The standards that used to focus on the operation and maintenance of each of the power system assets have now evolved to include diagnosis data analysis and information exchange and integration with other computer-based software and applications. The idea has been to concentrate

data and transform it into valuable information to produce cost-effective solutions with higher component reliability and power availability. Several initiatives have been put in practice, such as the IEC 61850 [255] (automation of substations), the distribution management systems (DMS), SCADA with a myriad of services and applications that use raw data to extract meaningful information for utility operation and maintenance.

The IEC 61968 [256] series is intended to support the inter-application integration of a utility enterprise that has different interfaces and run-time environments. It defines the major elements of an interface architecture for a Distribution Management System (DMS), covering not only asset management, but also network operation, planning, meter reading and control, common information model (CIM) profiles and MultiSpeak standards (standardization of interfaces among software applications). The IEC 61968-4:2019 [256] specifies the information exchange required for asset condition, analytics results and alerts, functional and lifecycle details, and asset's works.

The smart grid concept has been reliable for a while in power systems with the introduction of more capable intelligent electronic devices that coordinate operation locally and regionally. In the NIST Framework and Roadmap for Smart Grid Interoperability standards, the aim is to provide a consistent set of standards for the deployment of Smart Grids in the United States [261]. This includes maintenance automation and enabling predictive maintenance. A parallel initiative has been observed in the Industry 4.0 which integrates physical processes (hardware, software) with data exchange for obtaining valuable information with help of other technologies such cyber-physical systems, Internet of Things, cloud computing, etc., to create what is called the smart factory [261].

Beyond the smartness and the integration of cloud services, the power system is also rapidly evolving into a very complex meshed network where generation, transmission, and distribution is turning undistinguishable due to the deployment of smart devices, distributed generation, FACTS, and intelligent power conversion. In some cases, standards could be updated to face new conditions and provide meaningful additions to enhance usability of assets, but in other cases, the diversion from the original asset could be extreme. For example, being a transformer in principle, the solid-state transformer is a device with power electronics and pulsating operation, requiring a new maintenance standard on top of the standard for conventional transformers. The inclusion of more power electronics into the network can allow smarter protection systems, effective usage of renewables, coordinated operation across a region, but comes at the cost of conducting new research to produce new standards. These standards would contain guidelines for the operation and maintenance of physical apparatus, as well as guidelines on coding and maintainability of the electronics and communications that allow a 'data flow' in addition to the 'electricity flow' that exists since the early 1900s. Such challenge is not only a next step in the

TABLE 8. Existing Popular Maintenance Standards.

Entity	Standard(s)/ Technical Report	Topic	Reference
ISO	ISO 55000:2014	Overall asset management and asset management systems	[238]
	ISO 55001:2014		[239]
	ISO 55002:2018		[240]
	ISO 18095:2018	Power transformers	[240]
	ISO 18129:2015	Condition monitoring and diagnostics of machines	[244]
	ISO 19283:2020	Hydroelectric generating units	[249]
ISO	ISO 16079-1:2017	Wind Turbines	[247]
	ISO 16079-2:2020		[248]
IEC	IEC 60300 series	Dependability Management	[241]
	IEC 60706 series	Maintainability of equipment	[242]
	IEC 61709:2017 RLV	Failure rate data for reliability prediction of electric components	[246]
	IEC 62308:2006	Equipment Reliability assessment methods	[243]
	IEC TR 62978:2017	HVDC Installations	[257]
	IEC 61968-4:2019	System interfaces for distribution management	[256]
	IEC TS 62775:2016	Technical and financial processes	[258]
	IEC 61850:2022 SER Series	Communication networks and systems for power utility automation - ALL PARTS	[255]
CENELEC	SEGCG/M490/G_Smart Grid Set of Standards 23 Version 4.1	Asset and Maintenance Management system	[259]
NERC	PRC-005-6	Protection Systems	[254]
NIST	NIST Framework and Roadmap for Smart Grid Interoperability Standards, Release 1.0	Smart Grid infrastructure to enable predictive maintenance and maintenance automation	[260]
IEEE	IEEE C57.93-2019	Power Transformers	[251]
	IEEE 516-2021	Guide for Maintenance Methods on Energized Power Lines	[253]
	IEEE 492-1999	Guide for Operation and Maintenance of Hydro-Generators	[250]
	IEEE 1808-2011	Transmission Line Inspection and Maintenance	[252]
ANSI/NETA	ANSI/NETA MTS-2019	Maintenance Testing Specifications for Electrical Power Equipment and Systems	[245]
NIST	NIST 1108r3	NIST Framework and Roadmap for Smart Grid Interoperability standards	[261]

power systems maintenance, but a compulsory one to achieve resilience in times where climate change has produced so many power interruptions and asset damage across the globe. It is relevant to mention, that a summary of the most popular maintenance standards is presented in Table 8.

V. FUTURE PERSPECTIVES

This section aims to give perspectives regarding some challenges and opportunities, and provide an answer to the question MQ — **What are the future trends concerning power system maintenance?**

To answer the given question, it is necessary to identify the critical challenge that arises in the field of power system

maintenance planning from the perspective of Industry 4.0. In this sense, there is a need of modernize system generation in coordination with advanced maintenance strategies using information and communications technologies to a variety of advantages, such as, produce, transmit, and use energy in an environmentally responsible manner; reduce costs by improving operating efficiency and business practices, and enhance the reliability and quality of power supply [262], [263]. Advancements in the concept of the Internet of Energy (IoE) have been adopted [264]. The IoE provides a simple operation of the power system components controlled via an internet platform. In addition, IoE can capture the actual status of the component, which result convenient to

predict possible failures, and avoid them by taking maintenance actions. Therefore, to enhance maintenance planning, power systems must migrate to IoE technologies, becoming a trend in the power systems reliability field.

Currently, the power system operator focuses on supplying the demand of the consumers under restricted legislation [238]. However, such legislation does not necessarily include the conservation of optimum performance of the system by controlling the risks at restricted costs. In this context, SCADA emerges as a convenient solution to cover this gap, nonetheless, as the global population grows, strengthening SCADA will be necessary. This fact can be achieved with the inclusion of novel data acquisition technology, advanced algorithms, and more accurate modelling techniques than the existing ones. Attending to this need, an interesting and fashionable tool to enhance power system maintenance procedures is the use of robotics. Since the middle of the '80s, robots have been used to perform maintenance activities at the distribution level, such as insulator change or line restoration [265]. The system operates in a semi-automatic mode assisted by the operator. Although this robot provides a safe condition for the operator, its applications are limited if new renewable energy technologies are considered. Moreover, inspections and maintenance of these technologies demand time-consuming and involve risk for the personnel. For instance, in the scenario of wind turbines offshore, due to their location maintenance actions are complicated, and this will be executed if the weather and tide are favorable [266]. For this reason, nowadays some companies provide smart services that include inspections and onsite maintenance with remote-controlled using specialized drones. In fact, the maintenance can be performed during the operation of the wind turbine, reducing maintenance frequency procedures. Given the above, there is no doubt that the adaptability of robots in power systems is a field that requires to be exploited. Moreover, the incorporation of new internet technologies would be a stage in the direction of a fully autonomous power system industry.

Climate change is also a very important issue around the globe requiring changes to asset maintenance strategies. While the negative impact of climate change has driven the adoption of renewable energies [267], maintenance planning has not been developed to account for the changes in climate, as existing plans are largely focused on reducing costs rather than reducing climate change impact. Under this need, new maintenance paradigms are required that can support the reduction of greenhouse emissions. Moreover, with a view to promote a clean environment, a comprehensive maintenance standard that captures service life, system performance, and climate change must be introduced simultaneously.

For years, electric power utilities have focused strongly on the concept of system reliability. However, that single approach may not reflect the system performance overall [268]. For instance, during extreme weather and a secondary event (i.e., cyberattacks, earthquakes, wars, electric storms, wildfires, and as recently emerge, pandemics like

COVID-19), the situation becomes complex, and high system reliability may not capture adequately the system resilience. In this context, the key is being able to successfully move from a reliability-based strategy to a resiliency-based one. A resilient energy system is able to recover from catastrophic events by providing various means of supplying energy whenever there are changes in external circumstances. In order to strengthen system resiliency, the power grid must incorporate advanced forecast techniques that lead to an effective maintenance plan. Attention to events like wind direction during a tornado [269], the relationship between extreme wildfires and electric vehicles [270], weather prediction [271], and the COVID-19 pandemic effect on energy consumption [272], are topics that require novel approaches that may lead to more effective maintenance planning. The complicating factor is that, until now, resilience-based maintenance remains an ambiguous concept without a clear definition and robust regulation. There should be incentives, metrics, and appropriate modeling, to establish the foundations for a collaborative approach between the regulators, customers, and utilities to develop resilience-based maintenance schemes. This will require new holistic and state-of-the-art approaches based on digital data strategies with a focus on maintenance planning.

In summary, the future trends concerning power system maintenance prevails in the policies or standards to incorporated ICTs able to process data with modularity, decentralization, service orientation, virtualization, real-time capability, interoperability and be able to: 1. produce, transmit and use energy in an environmentally responsible manner; 2. reduce costs by improving operating efficiency and business practices, and; 3. enhance the reliability, resiliency and quality of power supply [262], [263].

VI. CONCLUDING REMARKS

This paper provides an extensive literature review of the application of maintenance in power systems over the last two decades. A comprehensive review of the evolution of maintenance strategies from corrective maintenance to asset management is provided, culminating in a taxonomy of maintenance strategies. It is evident the future is learning-oriented, self-regulated, intelligent maintenance that can maximize the technical and economic effectiveness of maintenance measures.

The use of new technologies, such as IoT, IoE, and maintenance robots, enables the system to become self-healing, self-sustaining, self-reliant, and smarter to minimize outage time and maximize component revenue. Considerations should be given not only to emerging technologies, but to techniques that can make the system smarter by collecting and integrating data through IoT devices, robotics tools and autonomous robots, Big Data analytics systems, AI and Cognitive systems, and finally Augmented and Virtual Reality. Improvements across machine learning techniques will govern the future of maintenance as the quality and duration of historical data increases. As climate continues to change, the frequency of extreme events is increasing, prompting a need

for resilient maintenance strategies that extend beyond traditional reliability-centric approaches. This provides a unique opportunity for future researchers to propose novel maintenance strategies with robust standards that integrate system reliability with resilience.

REFERENCES

- [1] M. A. Ponce-Jara, E. Ruiz, R. Gil, E. Sancristóbal, C. Pérez-Molina, and M. Castro, "Smart grid: Assessment of the past and present in developed and developing countries," *Energy Strategy Rev.*, vol. 18, pp. 38–52, Dec. 2017.
- [2] K. Breittfelder and D. Messina, *IEEE 100: The Authoritative Dictionary of IEEE Standards Terms*. Piscataway, NJ, USA: IEEE Press, 2000.
- [3] W. Li, *Reliability Assessment of Electric Power Systems Using Monte Carlo Methods*. New York, NY, USA: Springer, 2013.
- [4] M. Modarres, M. P. Kaminskiy, and V. Krivtsov, *Reliability Engineering and Risk Analysis: A Practical Guide*. Boca Raton, FL, USA: CRC Press, 2016.
- [5] R. Billinton and R. N. Allan, *Reliability Assessment of Large Electric Power Systems*. New York, NY, USA: Springer, 2012.
- [6] M. S. Alvarez-Alvarado and D. Jayaweera, "Aging reliability model for generation adequacy," in *Proc. IEEE Int. Conf. Probabilistic Methods Appl. Power Syst. (PMAPS)*, Jun. 2018, pp. 1–6.
- [7] K. Hou, H. Jia, X. Li, X. Xu, Y. Mu, T. Jiang, and X. Yu, "Impact-increment based decoupled reliability assessment approach for composite generation and transmission systems," *IET Gener., Transmiss. Distrib.*, vol. 12, no. 3, pp. 586–595, Feb. 2018.
- [8] S. Ahmadi, V. Vahidinasab, M. S. Ghazizadeh, K. Mehran, D. Giaouris, and P. Taylor, "Co-optimising distribution network adequacy and security by simultaneous utilisation of network reconfiguration and distributed energy resources," *IET Gener., Transmiss. Distrib.*, vol. 13, no. 20, pp. 4747–4755, Oct. 2019.
- [9] Y. Song, D. J. Hill, and T. Liu, "Static voltage stability analysis of distribution systems based on network-load admittance ratio," *IEEE Trans. Power Syst.*, vol. 34, no. 3, pp. 2270–2280, May 2019.
- [10] S. Karimi, P. Musilek, and A. M. Knight, "Dynamic thermal rating of transmission lines: A review," *Renew. Sustain. Energy Rev.*, vol. 91, pp. 600–612, Aug. 2018.
- [11] S. Ratra, R. Tiwari, and K. R. Niazi, "Voltage stability assessment in power systems using line voltage stability index," *Comput. Electr. Eng.*, vol. 70, pp. 199–211, Aug. 2018.
- [12] P. S. Kundur, N. J. Balu, and M. G. Lauby, "Power system dynamics and stability," in *Power System Stability and Control*, vol. 3. New York, NY, USA: McGraw-Hill, 2017.
- [13] A. Dixon, *Modern Aspects of Power System Frequency Stability and Control*. New York, NY, USA: Academic, 2019.
- [14] M. Ghafouri, M. Au, M. Kassouf, M. Debbabi, C. Assi, and J. Yan, "Detection and mitigation of cyber attacks on voltage stability monitoring of smart grids," *IEEE Trans. Smart Grid*, vol. 11, no. 6, pp. 5227–5238, Nov. 2020.
- [15] P. Poór, D. Zenisek, and J. Basl, "Historical overview of maintenance management strategies: Development from breakdown maintenance to predictive maintenance in accordance with four industrial revolutions," in *Proc. Int. Conf. Ind. Eng. Oper. Manage. (IEOM)*, 2019, pp. 495–504.
- [16] *A Guide to Managing Maintenance*, vol. 74, IACS, London, U.K., 2001.
- [17] P. R. Barnes, J. W. Van Dyke, B. W. McConnell, S. M. Cohn, and S. L. Purucker, "The feasibility of replacing or upgrading utility distribution transformers during routine maintenance," Oak Ridge Nat. Lab., Oak Ridge, TN, USA, Tech. Rep. 3445603874234, 1995.
- [18] P. Poor, J. Basl, and D. Zenisek, "Predictive maintenance 4.0 as next evolution step in industrial maintenance development," in *Proc. Int. Res. Conf. Smart Comput. Syst. Eng. (SCSE)*, Mar. 2019, pp. 245–253.
- [19] E. I. Basri, I. H. A. Razak, H. Ab-Samat, and S. Kamaruddin, "Preventive maintenance (PM) planning: A review," *J. Quality Maintenance Eng.*, vol. 23, no. 2, pp. 114–143, May 2017.
- [20] G. Niu, B.-S. Yang, and M. Pecht, "Development of an optimized condition-based maintenance system by data fusion and reliability-centered maintenance," *Rel. Eng. Syst. Saf.*, vol. 95, no. 7, pp. 786–796, Jul. 2010.
- [21] D. B. Durocher and G. R. Feldmeier, "Predictive versus preventive maintenance," *IEEE Ind. Appl. Mag.*, vol. 10, no. 5, pp. 12–21, Sep. 2004.
- [22] L. Bertling, "On evaluation of RCM for maintenance management of electric power systems," in *Proc. IEEE Power Eng. Soc. Gen. Meeting*, Jun. 2005, pp. 2638–2640.
- [23] *API Recommended Practice 580 Risk-Based Inspection*, Amer. Petroleum Inst., Washington, DC, USA, 2009.
- [24] A. Rojko, "Industry 4.0 concept: Background and overview," *Int. J. Interact. Mobile Technol.*, vol. 11, no. 5, p. 77, Jul. 2017.
- [25] J. Woodhouse, "Putting the total jigsaw puzzle together: PAS 55 standard for the integrated, optimized management of assets," in *Proc. Int. Maintenance Conf.*, 2006, pp. 1–12.
- [26] Y. Lu, "Cyber physical system (CPS)-based industry 4.0: A survey," *J. Ind. Integr. Manage.*, vol. 2, no. 3, Sep. 2017, Art. no. 1750014.
- [27] Z. Ding, T. Wu, and H. Shen, "Based on RFID and temperature tag smart inspection and maintenance technology for distribution power network," in *Proc. China Int. Conf. Electr. Distrib. (CICED)*, Aug. 2016, pp. 1–5.
- [28] M. Maritsch, C. Lesjak, and A. Aldrian, "Enabling smart maintenance services: Broker-based equipment status data acquisition and backend workflows," in *Proc. IEEE 14th Int. Conf. Ind. Informat. (INDIN)*, Jul. 2016, pp. 699–705.
- [29] J. D. Moseley, W. M. Grady, and S. Santoso, "New approaches for smart device integration and maintenance of power system models utilizing a unified data schema," in *Proc. IEEE PES Innov. Smart Grid Technol. Conf. (ISGT)*, Feb. 2013, pp. 1–6.
- [30] M. S. Alvarez-Alvarado and D. Jayaweera, "Reliability-based smart-maintenance model for power system generators," *IET Gener., Transmiss. Distrib.*, vol. 14, no. 9, pp. 1770–1780, May 2020.
- [31] M. S. Alvarez-Alvarado and D. Jayaweera, "Operational risk assessment with smart maintenance of power generators," *Int. J. Electr. Power Energy Syst.*, vol. 117, May 2020, Art. no. 105671.
- [32] Y. Shi, W. Zhu, Y. Xiang, and Q. Feng, "Condition-based maintenance optimization for multi-component systems subject to a system reliability requirement," *Rel. Eng. Syst. Saf.*, vol. 202, Oct. 2020, Art. no. 107042.
- [33] *Glossary of Terms Used in Terotechnology*, Standard BS 3811, 1993.
- [34] T.-H. Chen, W.-T. Huang, J.-C. Gu, G.-C. Pu, Y.-F. Hsu, and T.-Y. Guo, "Feasibility study of upgrading primary feeders from radial and open-loop to normally closed-loop arrangement," *IEEE Trans. Power Syst.*, vol. 19, no. 3, pp. 1308–1316, Aug. 2004.
- [35] H. Faria, Jr., J. G. S. Costa, and J. L. M. Olivias, "A review of monitoring methods for predictive maintenance of electric power transformers based on dissolved gas analysis," *Renew. Sustain. Energy Rev.*, vol. 46, pp. 201–209, Jun. 2015.
- [36] M. S. Alvarez-Alvarado, "Power system reliability enhancement with reactive power compensation and operational risk assessment with smart maintenance for power generators," Ph.D. dissertation, School Electron., Elect. Comput. Eng., Univ. Birmingham, Birmingham, U.K., 2020.
- [37] A. Abdulwhab and R. Billinton, "Application of wellbeing concepts in short term generating unit preventive maintenance scheduling," in *Proc. Can. Conf. Electr. Comput. Eng.*, vol. 1, May 2002, pp. 150–155.
- [38] R. Billinton and A. Abdulwhab, "Short-term generating unit maintenance scheduling in a deregulated power system using a probabilistic approach," *IEE Proc.-Gener., Transmiss. Distrib.*, vol. 150, no. 4, pp. 463–468, Jul. 2003.
- [39] R. Zheng and J. Zhong, "Generation adequacy assessment for power systems with wind turbine and energy storage," in *Proc. Innov. Smart Grid Technol. (ISGT)*, Jan. 2010, pp. 1–6.
- [40] R. Billinton and H. Yang, "Incorporating maintenance outage effects in substation and switching station reliability studies," in *Proc. Can. Conf. Electr. Comput. Eng.*, 2005, pp. 599–602.
- [41] V. Mijailovic, "Probabilistic method for planning of maintenance activities of substation components," *Electr. Power Syst. Res.*, vol. 64, no. 1, pp. 53–58, Jan. 2003.
- [42] S. Natti, P. Jirutitijaroen, M. Kezunovic, and C. Singh, "Circuit breaker and transformer inspection and maintenance: Probabilistic models," in *Proc. Int. Conf. Probabilistic Methods Appl. Power Syst.*, Sep. 2004, pp. 1003–1008.
- [43] J. Commerton, M. Zahzah, and Y. Khersonsky, "Solid state transfer switches and current interruptors for mission-critical shipboard power systems," in *Proc. IEEE Electr. Ship Technol. Symp.*, Jul. 2005, pp. 298–305.
- [44] M. S. Mashikian, "Preventive maintenance testing of shielded power cable systems," in *Proc. Annu. Pulp Paper Ind. Tech. Conf.*, Jun. 2001, pp. 59–66.
- [45] P. Pyy, "An analysis of maintenance failures at a nuclear power plant," *Rel. Eng. Syst. Saf.*, vol. 72, no. 3, pp. 293–302, Jun. 2001.

- [46] S. O. Oyedepo and F. R. Olayiwola, "A study of implementation of preventive maintenance programme in Nigeria power industry—Egbin thermal power plant, case study," *Energy Power Eng.*, vol. 3, no. 3, p. 207, 2011.
- [47] A. Ünsal, B. Mumyalmaz, and N. S. Tunaboylu, "Predicting the failures of transformers in a power system using the Poisson distribution: A case study," in *Proc. Int. Conf. Electr. Electron. Eng. (ELECO)*, 2005, pp. 1–4.
- [48] C. L. Melchor-Hernández, F. Rivas-Dávalos, S. Maximov, V. H. Coria, and J. L. Guardado, "A model for optimizing maintenance policy for power equipment," *Int. J. Electr. Power Energy Syst.*, vol. 68, pp. 304–312, Jun. 2015.
- [49] A. Nasr, S. Gasmi, and M. Sayadi, "Estimation of the parameters for a complex repairable system with preventive and corrective maintenance," in *Proc. Int. Conf. Electr. Eng. Softw. Appl.*, Mar. 2013, pp. 1–6.
- [50] H. Kim and C. Singh, "Reliability modeling and simulation in power systems with aging characteristics," *IEEE Trans. Power Syst.*, vol. 25, no. 1, pp. 21–28, Feb. 2010.
- [51] Y. Guessoum, A. Grall, A. Barros, and J. Aupied, "Modeling the gain due to maintenance over transformer lifespan," in *Proc. Annu. Rel. Maintainability Symp.*, Jan. 2011, pp. 1–6.
- [52] M. Lehtonen, "On the optimal strategies of condition monitoring and maintenance allocation in distribution systems," in *Proc. Int. Conf. Probabilistic Methods Appl. Power Syst.*, Jun. 2006, pp. 1–5.
- [53] T. M. Welte, J. Vatn, and J. Heggset, "Markov state model for optimization of maintenance and renewal of hydro power components," in *Proc. Int. Conf. Probabilistic Methods Appl. Power Syst.*, Jun. 2006, pp. 1–7.
- [54] H. George-Williams and E. Patelli, "Maintenance strategy optimization for complex power systems susceptible to maintenance delays and operational dynamics," *IEEE Trans. Rel.*, vol. 66, no. 4, pp. 1309–1330, Dec. 2017.
- [55] R.-C. Leou, "A flexible unit maintenance scheduling considering uncertainties," *IEEE Trans. Power Syst.*, vol. 16, no. 3, pp. 552–559, Aug. 2001.
- [56] C. Sharma and S. Bahadoorsingh, "A MATLAB-based power generator maintenance scheduler," in *Proc. IEEE PES Power Syst. Conf. Expo.*, Oct. 2004, pp. 1344–1348.
- [57] M. Alardhi and A. W. Labib, "Preventive maintenance scheduling of multi-co-generation plants using integer programming," *J. Oper. Res. Soc.*, vol. 59, no. 4, pp. 503–509, Apr. 2008.
- [58] M. Mollahassani-Pour, A. Abdollahi, and M. Rashidinejad, "Application of a novel cost reduction index to preventive maintenance scheduling," *Int. J. Electr. Power Energy Syst.*, vol. 56, pp. 235–240, Mar. 2014.
- [59] N. Tabari, S. Hassanpour, S. Hassanpour, and M. Pirmoradian, "A new approach for generation maintenance scheduling in a deregulated power system," in *Proc. IEEE Region 10 Conf. (TENCON)*, Nov. 2005, pp. 1–5.
- [60] A. F. Shahraki, O. P. Yadav, and C. Vogiatzis, "Selective maintenance optimization for multi-state systems considering stochastically dependent components and stochastic imperfect maintenance actions," *Rel. Eng. Syst. Saf.*, vol. 196, Apr. 2020, Art. no. 106738.
- [61] U. E. Ekpenyong, J. Zhang, and X. Xia, "An improved robust model for generator maintenance scheduling," *Electr. Power Syst. Res.*, vol. 92, pp. 29–36, Nov. 2012.
- [62] E. Umamaheswari, S. Ganesan, M. Abirami, and S. Subramanian, "Deterministic reliability model based preventive generator maintenance scheduling using ant lion optimizer," in *Proc. Int. Conf. Circuit, Power Comput. Technol. (ICCPCCT)*, Mar. 2016, pp. 1–8.
- [63] U. Elango, G. Sivarajan, A. Manoharan, and S. Srikrishna, "Preventive maintenance scheduling using analysis of variance-based ant lion optimizer," *World J. Eng.*, vol. 15, no. 2, pp. 254–272, Apr. 2018.
- [64] K. Suresh and N. Kumarappan, "Combined genetic algorithm and simulated annealing for preventive unit maintenance scheduling in power system," in *Proc. IEEE Power Eng. Soc. Gen. Meeting*, Jun. 2006, pp. 1–5.
- [65] Y. S. Duarte, J. Szytko, and A. M. D. C. Serpa, "Monte Carlo simulation model to coordinate the preventive maintenance scheduling of generating units in isolated distributed power systems," *Electr. Power Syst. Res.*, vol. 182, May 2020, Art. no. 106237.
- [66] M. Mirzadeh, M. Simab, and A. Ghaedi, "Adequacy studies of power systems with barrage-type tidal power plants," *IET Renew. Power Gener.*, vol. 13, no. 14, pp. 2612–2622, Oct. 2019.
- [67] L. S. M. Guedes, D. A. G. Vieira, A. C. Lisboa, and R. R. Saldanha, "A continuous compact model for cascaded hydro-power generation and preventive maintenance scheduling," *Int. J. Electr. Power Energy Syst.*, vol. 73, pp. 702–710, Dec. 2015.
- [68] A. N. Toutounchi, S. S. Shenava, S. Taheri, and H. Shayeghi, "MPEC approach for solving preventive maintenance scheduling of power units in a market environment," *Trans. Inst. Meas. Control*, vol. 40, no. 2, pp. 436–445, Jan. 2018.
- [69] M. Y. El-Sharkh and A. A. El-Keib, "An evolutionary programming-based solution methodology for power generation and transmission maintenance scheduling," *Electr. Power Syst. Res.*, vol. 65, no. 1, pp. 35–40, Apr. 2003.
- [70] R. Billinton and R. Mo, "Composite system maintenance coordination in a deregulated environment," *IEEE Trans. Power Syst.*, vol. 20, no. 1, pp. 485–492, Feb. 2005.
- [71] B. Falahati, Y. Fu, and M. J. Mousavi, "Reliability modeling and evaluation of power systems with smart monitoring," *IEEE Trans. Smart Grid*, vol. 4, no. 2, pp. 1087–1095, Jun. 2013.
- [72] A. Khosrojerdi, S. H. Zegordi, J. K. Allen, and F. Mistree, "A method for designing power supply chain networks accounting for failure scenarios and preventive maintenance," *Eng. Optim.*, vol. 48, no. 1, pp. 154–172, Jan. 2016.
- [73] P. Hilber, V. Miranda, M. A. Matos, and L. Bertling, "Multiobjective distribution applied to maintenance policy for electrical networks," *IEEE Trans. Power Syst.*, vol. 22, no. 4, pp. 1675–1682, Nov. 2007.
- [74] L. Bertling, R. Eriksson, and R. N. Allan, "Relation between preventive maintenance and reliability for a cost-effective distribution system," in *Proc. IEEE Porto Power Tech*, vol. 4, Sep. 2001, pp. 1–6.
- [75] O. Fouathia, J.-C. Maun, P.-E. Labeau, and D. Wiot, "Stochastic approach using Petri nets for maintenance optimization in Belgian power systems," in *Proc. Int. Conf. Probabilistic Methods Appl. Power Syst.*, Sep. 2004, pp. 168–173.
- [76] A. Sittithumwat, F. Soudi, and K. Tomsovic, "Optimal allocation of distribution maintenance resources with limited information," *Electr. Power Syst. Res.*, vol. 68, no. 3, pp. 208–220, Mar. 2004.
- [77] A. D. Janjic and D. S. Popovic, "Selective maintenance schedule of distribution networks based on risk management approach," *IEEE Trans. Power Syst.*, vol. 22, no. 2, pp. 597–604, May 2007.
- [78] S. K. Chen, T. K. Ho, and B. H. Mao, "Reliability evaluations of railway power supplies by fault-tree analysis," *IET Electr. Power Appl.*, vol. 1, no. 2, pp. 161–172, Mar. 2007.
- [79] M. Alimohammadi and J. Behnamian, "Preventive maintenance scheduling of electricity distribution network feeders to reduce undistributed energy: A case study in Iran," *Electr. Power Syst. Res.*, vol. 201, Dec. 2021, Art. no. 107509.
- [80] B. Wang, X. Wang, Z. Bie, P. D. Judge, X. Wang, and T. C. Green, "Reliability model of MMC considering periodic preventive maintenance," *IEEE Trans. Power Del.*, vol. 32, no. 3, pp. 1535–1544, Jun. 2017.
- [81] J. Gao, J. J. Chen, B. X. Qi, Y. L. Zhao, K. Peng, and X. H. Zhang, "A cost-effective two-stage optimization model for microgrid planning and scheduling with compressed air energy storage and preventive maintenance," *Int. J. Electr. Power Energy Syst.*, vol. 125, Feb. 2021, Art. no. 106547.
- [82] G. Parise and L. Martirano, "System management strategy to monitor insulated power cables," in *Proc. IEEE Ind. Appl. Conf., 39th IAS Annu. Meeting*, Oct. 2004, pp. 1755–1759.
- [83] H.-D. Chiang, H. Li, J. Tong, and P. Causgrove, "On-line voltage stability monitoring of large power systems," in *Proc. IEEE Power Energy Soc. Gen. Meeting*, Jul. 2011, pp. 1–6.
- [84] J. Zhao, L. Mili, and F. Milano, "Robust frequency divider for power system online monitoring and control," *IEEE Trans. Power Syst.*, vol. 33, no. 4, pp. 4414–4423, Jul. 2018.
- [85] S. K. Yang, "A condition-based failure-prediction and processing-scheme for preventive maintenance," *IEEE Trans. Rel.*, vol. 52, no. 3, pp. 373–383, Sep. 2003.
- [86] B. Jiang and A. Marnishev, "Robotic monitoring of power systems," *IEEE Trans. Power Del.*, vol. 19, no. 3, pp. 912–918, Jul. 2004.
- [87] S. K. Yang, "A condition-based preventive maintenance arrangement for thermal power plants," *Electr. Power Syst. Res.*, vol. 72, no. 1, pp. 49–62, Nov. 2004.
- [88] A. Sergaki and K. Kalaitzakis, "A fuzzy knowledge based method for maintenance planning in a power system," *Rel. Eng. Syst. Saf.*, vol. 77, no. 1, pp. 19–30, Jul. 2002.
- [89] S. Ambani, S. M. Meerkov, and L. Zhang, "Feasibility and optimization of preventive maintenance in exponential machines and serial lines," *IIE Trans.*, vol. 42, no. 10, pp. 766–777, Jul. 2010.
- [90] O. Ristic and V. Mijailovic, "Method for determining optimal power transformers exploitation strategy," *Electr. Power Syst. Res.*, vol. 83, no. 1, pp. 255–261, Feb. 2012.
- [91] Q. Xu, Y. Xu, P. Tu, T. Zhao, and P. Wang, "Systematic reliability modeling and evaluation for on-board power systems of more electric aircrafts," *IEEE Trans. Power Syst.*, vol. 34, no. 4, pp. 3264–3273, Jul. 2019.

- [92] N. Madzharov and P. Prodanov, "Analysis of reliability and preventive maintenance of wireless electrical vehicles charging station," in *Proc. AIP Conf.*, 2021, vol. 2333, no. 1, p. 90012.
- [93] M. S. Alvarez-Alvarado and D. Jayaweera, "Reliability model for a static Var compensator," in *Proc. IEEE 2nd Ecuador Tech. Chapters Meeting (ETCM)*, Oct. 2017, pp. 1–6.
- [94] I. P. Siqueira, "Optimum reliability-centered maintenance task frequencies for power system equipments," in *Proc. Int. Conf. Probabilistic Methods Appl. Power Syst.*, Sep. 2004, pp. 162–167.
- [95] B. Yssaad, M. Khiat, and A. Chaker, "Reliability centered maintenance optimization for power distribution systems," *Int. J. Electr. Power Energy Syst.*, vol. 55, pp. 108–115, Feb. 2014.
- [96] S. Peyghami, P. Palensky, M. Fotuhi-Firuzabad, and F. Blaabjerg, "System-level design for reliability and maintenance scheduling in modern power electronic-based power systems," *IEEE Open Access J. Power Energy*, vol. 7, pp. 414–429, 2020.
- [97] B. Liu, M. Xie, and W. Kuo, "Reliability modeling and preventive maintenance of load-sharing systems with degrading components," *IIE Trans.*, vol. 48, no. 8, pp. 699–709, Aug. 2016.
- [98] J. Jedrzejczak, G. J. Anders, M. Fotuhi-Firuzabad, H. Farzin, and F. Aminifar, "Reliability assessment of protective relays in harmonic-polluted power systems," *IEEE Trans. Power Del.*, vol. 32, no. 1, pp. 556–564, Feb. 2017.
- [99] I. W. Soro, M. Noureifath, and D. Ait-Kadi, "Performance evaluation of multi-state degraded systems with minimal repairs and imperfect preventive maintenance," *Rel. Eng. Syst. Saf.*, vol. 95, no. 2, pp. 65–69, Feb. 2010.
- [100] H. Ge, C. L. Tomasevicz, and S. Asgarpoor, "Optimum maintenance policy with inspection by semi-Markov decision processes," in *Proc. 39th North Amer. Power Symp.*, Sep. 2007, pp. 541–546.
- [101] S. Chen, T. Ho, and B. Mao, "Maintenance schedule optimisation for a railway power supply system," *Int. J. Prod. Res.*, vol. 51, no. 16, pp. 4896–4910, Aug. 2013.
- [102] D. D. Adhikary, G. K. Bose, D. K. Jana, D. Bose, and S. Mitra, "Availability and cost-centered preventive maintenance scheduling of continuous operating series systems using multi-objective genetic algorithm: A case study," *Qual. Eng.*, vol. 28, no. 3, pp. 352–357, Jul. 2016.
- [103] F. Moinian, H. Sabouhi, J. Hushmand, A. Hallaj, H. Khaleedi, and M. Mohammadpour, "Gas turbine preventive maintenance optimization using genetic algorithm," *Int. J. Syst. Assurance Eng. Manage.*, vol. 8, no. 3, pp. 594–601, Sep. 2017.
- [104] F. Yang, C. M. Kwan, and C. S. Chang, "Multiobjective evolutionary optimization of substation maintenance using decision-varying Markov model," *IEEE Trans. Power Syst.*, vol. 23, no. 3, pp. 1328–1335, Aug. 2008.
- [105] M. Aghaie, A. Norouzi, A. Zolfaghari, A. Minuchehr, Z. M. Fard, and R. Tumari, "Advanced progressive real coded genetic algorithm for nuclear system availability optimization through preventive maintenance scheduling," *Ann. Nucl. Energy*, vol. 60, pp. 64–72, Oct. 2013.
- [106] K. P. Dahal and N. Chakpitak, "Generator maintenance scheduling in power systems using metaheuristic-based hybrid approaches," *Electr. Power Syst. Res.*, vol. 77, no. 7, pp. 771–779, May 2007.
- [107] M. Žarković and Z. Stojković, "Analysis of artificial intelligence expert systems for power transformer condition monitoring and diagnostics," *Electr. Power Syst. Res.*, vol. 149, pp. 125–136, Aug. 2017.
- [108] J. Nilsson and L. Bertling, "Maintenance management of wind power systems using condition monitoring systems—Life cycle cost analysis for two case studies," *IEEE Trans. Energy Convers.*, vol. 22, no. 1, pp. 223–229, Mar. 2007.
- [109] E. Byon, L. Ntamo, and Y. Ding, "Optimal maintenance strategies for wind turbine systems under stochastic weather conditions," *IEEE Trans. Rel.*, vol. 59, no. 2, pp. 393–404, Jun. 2010.
- [110] M. Yildirim, N. Z. Gebrael, and X. A. Sun, "Integrated predictive analytics and optimization for opportunistic maintenance and operations in wind farms," *IEEE Trans. Power Syst.*, vol. 32, no. 6, pp. 4319–4328, Nov. 2017.
- [111] S. Zhong, A. A. Pantelous, M. Beer, and J. Zhou, "Constrained non-linear multi-objective optimisation of preventive maintenance scheduling for offshore wind farms," *Mech. Syst. Signal Process.*, vol. 104, pp. 347–369, May 2018.
- [112] S. Zhong, A. A. Pantelous, M. Goh, and J. Zhou, "A reliability-and-cost-based fuzzy approach to optimize preventive maintenance scheduling for offshore wind farms," *Mech. Syst. Signal Process.*, vol. 124, pp. 643–663, Jul. 2019.
- [113] M. Rashidnejad, S. Ebrahimnejad, and J. Safari, "A bi-objective model of preventive maintenance planning in distributed systems considering vehicle routing problem," *Comput. Ind. Eng.*, vol. 120, pp. 360–381, Jun. 2018.
- [114] K. Ayu and A. Yunusa-Kaltungo, "A holistic framework for supporting maintenance and asset management life cycle decisions for power systems," *Energies*, vol. 13, no. 8, p. 1937, Apr. 2020.
- [115] P. Mazidi and M. A. S. Bobi, "Strategic maintenance scheduling in an islanded microgrid with distributed energy resources," *Electr. Power Syst. Res.*, vol. 148, pp. 171–182, Jul. 2017.
- [116] B. Lin, J. Wu, R. Lin, J. Wang, H. Wang, and X. Zhang, "Optimization of high-level preventive maintenance scheduling for high-speed trains," *Rel. Eng. Syst. Saf.*, vol. 183, pp. 261–275, Mar. 2019.
- [117] P. S. Georgilakis, P. G. Vernados, and C. Karytsas, "An ant colony optimization solution to the integrated generation and transmission maintenance scheduling problem," *J. Optoelectron. Adv. Mater.*, vol. 10, no. 5, p. 1246, 2008.
- [118] L. Bertling, R. Allan, and R. Eriksson, "A reliability-centered asset maintenance method for assessing the impact of maintenance in power distribution systems," *IEEE Trans. Power Syst.*, vol. 20, no. 1, pp. 75–82, Feb. 2005.
- [119] R. Yousefian, R. Bhattarai, and S. Kamalasadani, "Transient stability enhancement of power grid with integrated wide area control of wind farms and synchronous generators," *IEEE Trans. Power Syst.*, vol. 32, no. 6, pp. 4818–4831, Nov. 2017.
- [120] N. Phoothong, P. Vanittanakom, N. Teera-Acharyakul, and D. Rerkpreedapong, "Optimal preventive maintenance budget setting for electric power distribution utilities," in *Proc. 5th Int. Conf. Electr. Eng./Electron., Comput., Telecommun. Inf. Technol.*, vol. 2, May 2008, pp. 957–960.
- [121] B. Cai, Y. Liu, Q. Fan, Y. Zhang, S. Yu, Z. Liu, and X. Dong, "Performance evaluation of subsea BOP control systems using dynamic Bayesian networks with imperfect repair and preventive maintenance," *Eng. Appl. Artif. Intel.*, vol. 26, no. 10, pp. 2661–2672, 2013.
- [122] Y.-R. Wu and H.-S. Zhao, "Optimization maintenance of wind turbines using Markov decision processes," in *Proc. Int. Conf. Power Syst. Technol.*, Oct. 2010, pp. 1–6.
- [123] F. Besnard, J. Nilsson, and L. Bertling, "On the economic benefits of using condition monitoring systems for maintenance management of wind power systems," in *Proc. IEEE 11th Int. Conf. Probabilistic Methods Appl. Power Syst.*, Jun. 2010, pp. 160–165.
- [124] T. K. Ho, Y. L. Chi, L. Ferreira, K. K. Leung, and L. K. Siu, "Evaluation of maintenance schedules on railway traction power systems," *Proc. Inst. Mech. Eng., F, J. Rail Rapid Transit*, vol. 220, no. 2, pp. 91–102, Mar. 2006.
- [125] M. Jadidbonab, H. Mousavi-Sarabi, and B. Mohammadi-Ivatloo, "Risk-constrained scheduling of solar-based three state compressed air energy storage with waste thermal recovery unit in the thermal energy market environment," *IET Renew. Power Gener.*, vol. 13, no. 6, pp. 920–929, Apr. 2019.
- [126] M. Y. El-Sharkh and A. A. El-Keib, "Maintenance scheduling of generation and transmission systems using fuzzy evolutionary programming," *IEEE Trans. Power Syst.*, vol. 18, no. 2, pp. 862–866, May 2003.
- [127] P. Jirutitjaroen and C. Singh, "The effect of transformer maintenance parameters on reliability and cost: A probabilistic model," *Electr. Power Syst. Res.*, vol. 72, no. 3, pp. 213–224, 2004.
- [128] J. Wang, X. Zhang, J. Zeng, and Y. Zhang, "Optimal dynamic imperfect preventive maintenance of wind turbines based on general renewal processes," *Int. J. Prod. Res.*, vol. 58, no. 22, pp. 6791–6810, Nov. 2020.
- [129] M. Shafiee, M. Patriksson, and A.-B. Strömberg, "An optimal number-dependent preventive maintenance strategy for offshore wind turbine blades considering logistics," *Adv. Oper. Res.*, vol. 2013, pp. 1–12, Jan. 2013.
- [130] A. Moradkhani, M. R. Haghifam, and S. M. Abedi, "Risk-based maintenance scheduling in the presence of reward penalty scheme," *Electr. Power Syst. Res.*, vol. 121, pp. 126–133, Apr. 2015.
- [131] L. X. Min, W. J. Yong, Y. Yuan, and X. W. Yan, "Multiobjective optimization of preventive maintenance schedule on traction power system in high-speed railway," in *Proc. Annu. Rel. Maintainability Symp.*, Jan. 2009, pp. 365–370.
- [132] *External Report on Maintenance Schedule Checklist for GEPC—RM Commissioning & Services Hydro Generators*, General Electric, Schenectady, NY, USA, 2017.
- [133] A. Raza and V. Ulansky, "Optimal preventive maintenance of wind turbine components with imperfect continuous condition monitoring," *Energies*, vol. 12, no. 19, p. 3801, Oct. 2019.

- [134] A. Abiri-Jahromi, M. Parvania, F. Bouffard, and M. Fotuhi-Firuzabad, "a two-stage framework for power transformer asset maintenance management—Part I: Models and formulations," *IEEE Trans. Power Syst.*, vol. 28, no. 2, pp. 1395–1403, May 2013.
- [135] P. Dehghanian, M. Fotuhi-Firuzabad, F. Aminifar, and R. Billinton, "A comprehensive scheme for reliability-centered maintenance in power distribution systems—Part II: Numerical analysis," *IEEE Trans. Power Del.*, vol. 28, no. 2, pp. 771–778, Apr. 2013.
- [136] X. Zhang and E. Gockenbach, "Age-dependent maintenance strategies of medium-voltage circuit-breakers and transformers," *Electr. Power Syst. Res.*, vol. 81, no. 8, pp. 1709–1714, Aug. 2011.
- [137] P. Dehghanian and M. Kezunovic, "Cost/benefit analysis for circuit breaker maintenance planning and scheduling," in *Proc. North Amer. Power Symp. (NAPS)*, Sep. 2013, pp. 1–6.
- [138] A. Arab, E. Tekin, A. Khodaei, S. K. Khator, and Z. Han, "System hardening and condition-based maintenance for electric power infrastructure under hurricane effects," *IEEE Trans. Rel.*, vol. 65, no. 3, pp. 1457–1470, Sep. 2016.
- [139] B. R. Sarker and T. I. Faiz, "Minimizing maintenance cost for offshore wind turbines following multi-level opportunistic preventive strategy," *Renew. Energy*, vol. 85, pp. 104–113, Jan. 2016.
- [140] G. Biard and G. A. Nour, "Industry 4.0 contribution to asset management in the electrical industry," *Sustainability*, vol. 13, no. 18, p. 10369, Sep. 2021.
- [141] S. Amelete, R. Vaillancourt, G. Abdul-Nour, and F. Gauthier, "Asset management, industry 4.0 and maintenance in electrical energy distribution," in *Proc. IFIP Int. Conf. Adv. Prod. Manage. Syst.*, 2021, pp. 199–208.
- [142] A. Valencia and J. D. Pinzon, "Asset management model of SCADA infrastructure of power control centers based on indicators," in *Proc. IEEE PES Innov. Smart Grid Technol. Conf.-Latin Amer. (ISGT Latin Amer.)*, Sep. 2021, pp. 1–5.
- [143] A. J. Conejo, R. Garcia-Bertrand, and M. Diaz-Salazar, "Generation maintenance scheduling in restructured power systems," *IEEE Trans. Power Syst.*, vol. 20, no. 2, pp. 984–992, May 2005.
- [144] P. Michalopoulos, F. D. Kanellos, G. J. Tsekouras, and J. M. Prousalidis, "A method for optimal operation of complex ship power systems employing shaft electric machines," *IEEE Trans. Transport. Electrification*, vol. 2, no. 4, pp. 547–557, Dec. 2016.
- [145] F. Besnard, M. Patriksson, A.-B. Stromberg, A. Wojciechowski, and L. Bertling, "An optimization framework for opportunistic maintenance of offshore wind power system," in *Proc. IEEE Bucharest PowerTech*, Jun. 2009, pp. 1–7.
- [146] A. Abiri-Jahromi, M. Fotuhi-Firuzabad, and M. Parvania, "Optimized midterm preventive maintenance outage scheduling of thermal generating units," *IEEE Trans. Power Syst.*, vol. 27, no. 3, pp. 1354–1365, Aug. 2012.
- [147] S. Perez-Canto and J. C. Rubio-Romero, "A model for the preventive maintenance scheduling of power plants including wind farms," *Rel. Eng. Syst. Saf.*, vol. 119, pp. 67–75, Nov. 2013.
- [148] A. Fetanat and G. Shafipour, "Generation maintenance scheduling in power systems using ant colony optimization for continuous domains based 0–1 integer programming," *Expert Syst. Appl.*, vol. 38, no. 8, pp. 9729–9735, Aug. 2011.
- [149] C. M. F. Lapa, C. M. N. A. Pereira, and M. P. de Barros, "A model for preventive maintenance planning by genetic algorithms based in cost and reliability," *Rel. Eng. Syst. Saf.*, vol. 91, no. 2, pp. 233–240, 2006.
- [150] C. M. N. A. Pereira, C. M. F. Lapa, A. C. A. Mol, and A. F. da Luz, "A particle swarm optimization (PSO) approach for non-periodic preventive maintenance scheduling programming," *Prog. Nucl. Energy*, vol. 52, no. 8, pp. 710–714, Nov. 2010.
- [151] E. Umamaheswari, S. Ganesan, M. Abirami, and S. Subramanian, "Reliability/risk centered cost effective preventive maintenance planning of generating units," *Int. J. Quality Rel. Manage.*, vol. 35, no. 9, pp. 2052–2079, Oct. 2018.
- [152] M. Yildirim, X. A. Sun, and N. Z. Gebraeel, "sensor-driven condition-based generator maintenance scheduling—Part I: Maintenance problem," *IEEE Trans. Power Syst.*, vol. 31, no. 6, pp. 4253–4262, Nov. 2016.
- [153] M. Yildirim, X. A. Sun, and N. Z. Gebraeel, "Sensor-driven condition-based generator maintenance scheduling—Part II: Incorporating operations," *IEEE Trans. Power Syst.*, vol. 31, no. 6, pp. 4263–4271, Nov. 2016.
- [154] M. Alardhi, R. G. Hannam, and A. W. Labib, "Preventive maintenance scheduling for multi-cogeneration plants with production constraints," *J. Quality Maintenance Eng.*, vol. 13, no. 3, pp. 276–292, Aug. 2007.
- [155] L. Wu, M. Shahidehpour, and T. Li, "GENCO's risk-based maintenance outage scheduling," *IEEE Trans. Power Syst.*, vol. 23, no. 1, pp. 127–136, Feb. 2008.
- [156] B. G. Lindner, R. Brits, J. H. van Vuuren, and J. Bekker, "Tradeoffs between levelling the reserve margin and minimising production cost in generator maintenance scheduling for regulated power systems," *Int. J. Electr. Power Energy Syst.*, vol. 101, pp. 458–471, Oct. 2018.
- [157] T. Geetha and K. S. Swarup, "Coordinated preventive maintenance scheduling of GENCO and TRANSCO in restructured power systems," *Int. J. Electr. Power Energy Syst.*, vol. 31, no. 10, pp. 626–638, Nov. 2009.
- [158] Y. Wang, Z. Li, M. Shahidehpour, L. Wu, C. X. Guo, and B. Zhu, "Stochastic co-optimization of midterm and short-term maintenance outage scheduling considering covariates in power systems," *IEEE Trans. Power Syst.*, vol. 31, no. 6, pp. 4795–4805, Nov. 2016.
- [159] A. Arab, E. Tekin, A. Khodaei, S. K. Khator, and Z. Han, "Dynamic maintenance scheduling for power systems incorporating hurricane effects," in *Proc. IEEE Int. Conf. Smart Grid Commun. (SmartGridComm)*, Nov. 2014, pp. 85–90.
- [160] M. Fattahi, M. Mahootchi, H. Mosadegh, and F. Fallahi, "A new approach for maintenance scheduling of generating units in electrical power systems based on their operational hours," *Comput. Oper. Res.*, vol. 50, pp. 61–79, Jan. 2014.
- [161] K. B. Vakkapatla and S. V. Pinni, "Generation rescheduling using multiobjective bilevel optimization," *Turkish J. Electr. Eng. Comput. Sci.*, vol. 27, no. 3, pp. 2086–2096, 2019.
- [162] L. Moyo, N. I. Nwulu, U. E. Ekpenyong, and R. C. Bansal, "A tri-objective model for generator maintenance scheduling," *IEEE Access*, vol. 9, pp. 136384–136394, 2021.
- [163] R. Eshraghnia, M. H. M. Shanечи, and H. R. Mashhadi, "A new approach for maintenance scheduling of generating units in power market," in *Proc. Int. Conf. Probabilistic Methods Appl. Power Syst.*, Jun. 2006, pp. 1–7.
- [164] F. Yang and C. S. Chang, "Multiobjective evolutionary optimization of maintenance schedules and extents for composite power systems," *IEEE Trans. Power Syst.*, vol. 24, no. 4, pp. 1694–1702, Nov. 2009.
- [165] J. Wang, J. Lu, Z. Bie, S. You, and X. Cao, "Long-term maintenance scheduling of smart distribution system through a PSO-TS algorithm," *J. Appl. Math.*, vol. 2014, pp. 1–12, Jan. 2014.
- [166] Y. Li, S. Yeddapanadi, J. D. McCalley, A. A. Chowdhury, and W. Jewell, "Resource management for distribution system maintenance using optimized risk reduction," in *Proc. Int. Conf. Probabilistic Methods Appl. Power Syst.*, Jun. 2006, pp. 1–6.
- [167] A. Koksal and A. Ozdemir, "Improved transformer maintenance plan for reliability centred asset management of power transmission system," *IET Gener., Transmiss. Distrib.*, vol. 10, no. 8, pp. 1976–1983, May 2016.
- [168] F. Liu, H. Dui, and Z. Li, "Reliability analysis for electrical power systems based on importance measures," *Proc. Inst. Mech. Eng., O, J. Risk Rel.*, vol. 236, no. 2, pp. 317–328, 2019.
- [169] M. H. Firouz and N. Ghadimi, "Optimal preventive maintenance policy for electric power distribution systems based on the fuzzy AHP methods," *Complexity*, vol. 21, no. 6, pp. 70–88, Jul. 2016.
- [170] M. K. Tehrani, A. Fereidunian, and H. Lesani, "Financial planning for the preventive maintenance of power distribution systems via fuzzy AHP," *Complexity*, vol. 21, no. 3, pp. 36–46, Jan. 2016.
- [171] D. Piasson, A. A. P. Biscoar, F. B. Leão, and J. R. S. Mantovani, "A new approach for reliability-centered maintenance programs in electric power distribution systems based on a multiobjective genetic algorithm," *Electr. Power Syst. Res.*, vol. 137, pp. 41–50, Aug. 2016.
- [172] L. S. Moulin, A. P. A. da Silva, M. A. El-Sharkawi, and R. J. Marks, "Support vector machines for transient stability analysis of large-scale power systems," *IEEE Trans. Power Syst.*, vol. 19, no. 2, pp. 818–825, May 2004.
- [173] L. Yin, L. Zhao, T. Yu, and X. Zhang, "Deep forest reinforcement learning for preventive strategy considering automatic generation control in large-scale interconnected power systems," *Appl. Sci.*, vol. 8, no. 11, p. 2185, Nov. 2018.
- [174] D. Panatsesky, D. Sidorov, Y. Li, L. Ouyang, J. Xiong, and L. He, "Centralized emergency control for multi-terminal VSC-based shipboard power systems," *Int. J. Electr. Power Energy Syst.*, vol. 104, pp. 205–214, Jan. 2019.
- [175] F. D. Kanellos, J. M. Prousalidis, and G. J. Tsekouras, "Control system for fuel consumption minimization—gas emission limitation of full electric propulsion ship power systems," *Proc. Inst. Mech. Eng., M, J. Eng. Maritime Environ.*, vol. 228, no. 1, pp. 17–28, Feb. 2014.

- [176] M. Mollahassani-Pour, A. Abdollahi, and M. Rashidinejad, "Investigation of market-based demand response impacts on security-constrained preventive maintenance scheduling," *IEEE Syst. J.*, vol. 9, no. 4, pp. 1496–1506, Dec. 2015.
- [177] J. Liu, Y. Xu, Z. Y. Dong, and K. P. Wong, "Retirement-driven dynamic VAR planning for voltage stability enhancement of power systems with high-level wind power," *IEEE Trans. Power Syst.*, vol. 33, no. 2, pp. 2282–2291, Mar. 2018.
- [178] M. S. Alvarez-Alvarado and D. Jayaweera, "Smart maintenance model for operational planning of static synchronous compensators," in *Proc. IEEE Milan PowerTech*, Jun. 2019, pp. 1–6.
- [179] H. Mo, G. Sansavini, and M. Xie, "Performance-based maintenance of gas turbines for reliable control of degraded power systems," *Mech. Syst. Signal Process.*, vol. 103, pp. 398–412, Mar. 2018.
- [180] R. Kaluthantrige and A. D. Rajapakse, "Evaluation of hierarchical controls to manage power, energy and daily operation of remote off-grid power systems," *Appl. Energy*, vol. 299, Oct. 2021, Art. no. 117259.
- [181] M. A. Vogelsberger, T. Wiesinger, and H. Ertl, "Life-cycle monitoring and voltage-managing unit for DC-link electrolytic capacitors in PWM converters," *IEEE Trans. Power Electron.*, vol. 26, no. 2, pp. 493–503, Feb. 2011.
- [182] W. Huang and K. Sun, "Optimization of SVC settings to improve post-fault voltage recovery and angular stability," *J. Mod. Power Syst. Clean Energy*, vol. 7, no. 3, pp. 491–499, May 2019.
- [183] L. Duchesne, E. Karangelos, and L. Wehenkel, "Recent developments in machine learning for energy systems reliability management," *Proc. IEEE*, vol. 108, no. 9, pp. 1656–1676, Sep. 2020.
- [184] C. Liu, K. Sun, Z. H. Rather, Z. Chen, C. L. Bak, P. Thøgersen, and P. Lund, "A systematic approach for dynamic security assessment and the corresponding preventive control scheme based on decision trees," *IEEE Trans. Power Syst.*, vol. 29, no. 2, pp. 717–730, Mar. 2014.
- [185] H. Mohammadi and M. Dehghani, "PMU based voltage security assessment of power systems exploiting principal component analysis and decision trees," *Int. J. Electr. Power Energy Syst.*, vol. 64, pp. 655–663, Jan. 2015.
- [186] B. Basciftci, S. Ahmed, and N. Gebrael, "Data-driven maintenance and operations scheduling in power systems under decision-dependent uncertainty," *IIEE Trans.*, vol. 52, no. 6, pp. 589–602, Jun. 2020.
- [187] M. J. Kim, T. S. Kim, R. J. Flores, and J. Brouwer, "Neural-network-based optimization for economic dispatch of combined heat and power systems," *Appl. Energy*, vol. 265, May 2020, Art. no. 114785.
- [188] S. Y. Wong, X. Ye, F. Guo, and H. H. Goh, "Computational intelligence for preventive maintenance of power transformers," *Appl. Soft Comput.*, vol. 114, Jan. 2022, Art. no. 108129.
- [189] F. Pourahmadi, M. Fotuhi-Firuzabad, and P. Dehghanian, "Application of game theory in reliability-centered maintenance of electric power systems," *IEEE Trans. Ind. Appl.*, vol. 53, no. 2, pp. 936–946, Mar./Apr. 2017.
- [190] Q. Wu, Q. Feng, Y. Ren, Q. Xia, Z. Wang, and B. Cai, "An intelligent preventive maintenance method based on reinforcement learning for battery energy storage systems," *IEEE Trans. Ind. Inform.*, vol. 17, no. 12, pp. 8254–8264, Dec. 2021.
- [191] Y. Liu, Y. Li, H.-Z. Huang, M. J. Zuo, and Z. Sun, "Optimal preventive maintenance policy under fuzzy Bayesian reliability assessment environments," *IIE Trans.*, vol. 42, no. 10, pp. 734–745, Jul. 2010.
- [192] E. Özcan, T. Danişan, R. Yumuşak, and T. Eren, "An artificial neural network model supported with multi criteria decision making approaches for maintenance planning in hydroelectric power plants," *Eksploatacja Niezawodnosć-Maintenance Rel.*, vol. 22, no. 3, pp. 400–418, Jun. 2020.
- [193] S. M. Ashraf, A. Gupta, D. K. Choudhary, and S. Chakrabarti, "Voltage stability monitoring of power systems using reduced network and artificial neural network," *Int. J. Electr. Power Energy Syst.*, vol. 87, pp. 43–51, May 2017.
- [194] Q. Wang, C. Zhang, Y. Lü, Z. Yu, and Y. Tang, "Data inheritance-based updating method and its application in transient frequency prediction for a power system," *Int. Trans. Electr. Energy Syst.*, vol. 29, no. 6, Jun. 2019, Art. no. e12022.
- [195] J. Sun, Z. Zhu, H. Li, Y. Chai, G. Qi, H. Wang, and Y. H. Hu, "An integrated critic-actor neural network for reinforcement learning with application of DERs control in grid frequency regulation," *Int. J. Electr. Power Energy Syst.*, vol. 111, pp. 286–299, Oct. 2019.
- [196] C. Mu, Y. Tang, and H. He, "Improved sliding mode design for load frequency control of power system integrated an adaptive learning strategy," *IEEE Trans. Ind. Electron.*, vol. 64, no. 8, pp. 6742–6751, Aug. 2017.
- [197] D. Xu, J. Liu, X.-G. Yan, and W. Yan, "A novel adaptive neural network constrained control for a multi-area interconnected power system with hybrid energy storage," *IEEE Trans. Ind. Electron.*, vol. 65, no. 8, pp. 6625–6634, Aug. 2018.
- [198] H. Fan, Y. Chen, S. Huang, X. Zhang, H. Guan, and D. Shi, "Post-fault transient stability assessment based on k -nearest neighbor algorithm with Mahalanobis distance," in *Proc. Int. Conf. Power Syst. Technol. (POWERCON)*, Nov. 2018, pp. 4417–4423.
- [199] S. S. Maaji, G. Cosma, A. Taherkhani, A. A. Alani, and T. M. McGinnity, "On-line voltage stability monitoring using an ensemble AdaBoost classifier," in *Proc. 4th Int. Conf. Inf. Manage. (ICIM)*, May 2018, pp. 253–259.
- [200] B. Wang, B. Fang, Y. Wang, H. Liu, and Y. Liu, "Power system transient stability assessment based on big data and the core vector machine," *IEEE Trans. Smart Grid*, vol. 7, no. 5, pp. 2561–2570, Sep. 2016.
- [201] W. Hu, Z. Lu, S. Wu, W. Zhang, Y. Dong, R. Yu, and B. Liu, "Real-time transient stability assessment in power system based on improved SVM," *J. Mod. Power Syst. Clean Energy*, vol. 7, no. 1, pp. 26–37, Jan. 2019.
- [202] Y. Zhou, J. Wu, Z. Yu, L. Ji, and L. Hao, "A hierarchical method for transient stability prediction of power systems using the confidence of a SVM-based ensemble classifier," *Energies*, vol. 9, no. 10, p. 778, Sep. 2016.
- [203] H. Mohammadi, G. Khademi, M. Dehghani, and D. Simon, "Voltage stability assessment using multi-objective biogeography-based subset selection," *Int. J. Electr. Power Energy Syst.*, vol. 103, pp. 525–536, Dec. 2018.
- [204] N. V. Tomin, V. G. Kurbatsky, D. N. Sidorov, and A. V. Zhukov, "Machine learning techniques for power system security assessment," *IFAC-PapersOnLine*, vol. 49, no. 27, pp. 445–450, 2016.
- [205] F. R. Gomez, A. Rajapakse, U. Annakkage, and I. Fernando, "Support vector machine-based algorithm for post-fault transient stability status prediction using synchronized measurements," *IEEE Trans. Power Syst.*, vol. 26, no. 3, pp. 1474–1483, Aug. 2011.
- [206] J. Kang, Z. Wang, and C. G. Soares, "Condition-based maintenance for offshore wind turbines based on support vector machine," *Energies*, vol. 13, no. 14, p. 3518, Jul. 2020.
- [207] B. Denis, K. Dmitriy, I. Dmitriy, and S. Denis, "Machine learning in electric power systems adequacy assessment using monte-carlo method," in *Proc. Int. Multi-Conf. Eng., Comput. Inf. Sci. (SIBIRCON)*, Sep. 2017, pp. 201–205.
- [208] L. C. Resende, L. A. F. Manso, W. D. Dutra, and A. M. L. da Silva, "Support vector machine application in composite reliability assessment," in *Proc. 18th Int. Conf. Intell. Syst. Appl. Power Syst. (ISAP)*, Sep. 2015, pp. 1–6.
- [209] M. Glavic, R. Fonteneau, and D. Ernst, "Reinforcement learning for electric power system decision and control: Past considerations and perspectives," *IFAC-PapersOnLine*, vol. 50, no. 1, pp. 6918–6927, Jul. 2017.
- [210] S. Kamlu and V. Laxmi, "Condition-based maintenance strategy for vehicles using hidden Markov models," *Adv. Mech. Eng.*, vol. 11, no. 1, 2019, Art. no. 1687814018806380.
- [211] F. Sotiropoulos, P. Alefragis, and E. Housos, "A hidden Markov models tool for estimating the deterioration level of a power transformer," in *Proc. IEEE Conf. Emerg. Technol. Factory Autom. (EFTA)*, Sep. 2007, pp. 784–787.
- [212] A. D. Kenyon, V. M. Catterson, S. D. J. McArthur, and J. Twiddle, "An agent-based implementation of hidden Markov models for gas turbine condition monitoring," *IEEE Trans. Syst., Man, Cybern., Syst.*, vol. 44, no. 2, pp. 186–195, Feb. 2014.
- [213] D. Bhaumik, D. Crommelin, S. Kapodistria, and B. Zwart, "Hidden Markov models for wind farm power output," *IEEE Trans. Sustain. Energy*, vol. 10, no. 2, pp. 533–539, Apr. 2019.
- [214] M. E. Cholette and D. Djurdjanovic, "Degradation modeling and monitoring of machines using operation-specific hidden Markov models," *IIE Trans.*, vol. 46, no. 10, pp. 1107–1123, Oct. 2014.
- [215] Y. Fan, J. Li, D. Zhang, J. Pi, J. Song, and G. Zhao, "Supporting sustainable maintenance of substations under cyber-threats: An evaluation method of cybersecurity risk for power CPS," *Sustainability*, vol. 11, no. 4, p. 982, Feb. 2019.
- [216] I. N. Fovino, L. Guidi, M. Masera, and A. Stefanini, "Cyber security assessment of a power plant," *Electr. Power Syst. Res.*, vol. 81, no. 2, pp. 518–526, 2011.
- [217] A. Dagoumas, "Assessing the impact of cybersecurity attacks on power systems," *Energies*, vol. 12, no. 4, p. 725, Feb. 2019.
- [218] O. Tor and M. Shahidehpour, "Power distribution asset management," in *Proc. IEEE Power Eng. Soc. Gen. Meeting*, Jun. 2006, pp. 1–7.

- [219] I. Ivanković, D. Peharda, D. Novosel, K. Žubrinić-Kostović, and A. Kekelj, "Smart grid substation equipment maintenance management functionality based on control center SCADA data," *J. Energy Energ.*, vol. 67, no. 3, pp. 1–6, 2018.
- [220] A. J. Holmgren, E. Jenelius, and J. Westin, "Evaluating strategies for defending electric power networks against antagonistic attacks," *IEEE Trans. Power Syst.*, vol. 22, no. 1, pp. 76–84, Feb. 2007.
- [221] S. Pan, T. Morris, and U. Adhikari, "Developing a hybrid intrusion detection system using data mining for power systems," *IEEE Trans. Smart Grid*, vol. 6, no. 6, pp. 3104–3113, Nov. 2015.
- [222] Q. Li, S. Meng, S. Zhang, M. Wu, J. Zhang, M. T. Ahvanooy, and M. S. Aslam, "Safety risk monitoring of cyber-physical power systems based on ensemble learning algorithm," *IEEE Access*, vol. 7, pp. 24788–24805, 2019.
- [223] C.-C. Sun, A. Hahn, and C.-C. Liu, "Cyber security of a power grid: State-of-the-art," *Int. J. Elect. Power Energy Syst.*, vol. 99, pp. 45–56, Jul. 2018.
- [224] C.-C. Sun, C.-C. Liu, and J. Xie, "Cyber-physical system security of a power grid: State-of-the-art," *Electronics*, vol. 5, no. 4, p. 40, Jul. 2016.
- [225] G. Liang, J. Zhao, F. Luo, S. R. Weller, and Z. Y. Dong, "A review of false data injection attacks against modern power systems," *IEEE Trans. Smart Grid*, vol. 8, no. 4, pp. 1630–1638, Jul. 2017.
- [226] B. Shakerighadi, A. Anvari-Moghaddam, J. Vasquez, and J. Guerrero, "Internet of Things for modern energy systems: State-of-the-art, challenges, and open issues," *Energies*, vol. 11, no. 5, p. 1252, May 2018.
- [227] M. S. Alvarez-Alvarado and D. Jayaweera, "Bathtub curve as a Markovian process to describe the reliability of repairable components," *IET Gener., Transmiss. Distrib.*, vol. 12, no. 21, pp. 5683–5689, Nov. 2018.
- [228] M. S. Alvarez-Alvarado, F. E. Alban-Chacón, E. A. Lamilla-Rubio, C. D. Rodríguez-Gallegos, and W. Velásquez, "Three novel quantum-inspired swarm optimization algorithms using different bounded potential fields," *Sci. Rep.*, vol. 11, no. 1, pp. 1–22, Dec. 2021.
- [229] *ISO Standards are Internationally Agreed by Experts*. Accessed: Oct. 2021. [Online]. Available: <https://www.iso.org/standards.html>
- [230] *IEC Everywhere for a Safer and More Efficient World*. Accessed: Oct. 2021. [Online]. Available: <https://iec.ch/homepage>
- [231] *IEEE Standard Association*. Accessed: Oct. 2021. [Online]. Available: <https://standards.ieee.org/>
- [232] *North American Electric Reliability Corporation*. Accessed: Oct. 2021. [Online]. Available: <https://www.nerc.com/Pages/default.aspx>
- [233] *Commission Européenne de Normalisation Electrique*. Accessed: Oct. 2021. [Online]. Available: <https://www.cenelec.eu/>
- [234] *American National Standards Institute*. Accessed: Oct. 2021. [Online]. Available: <http://ansi.org>
- [235] *British Standards Institute*. Accessed: Oct. 2021. [Online]. Available: <https://www.bsigroup.com/en-GB/>
- [236] *Standardization Administration of China*. Accessed: Oct. 2021. [Online]. Available: <http://www.sac.gov.cn/sac/en/>
- [237] *European Standardization*. Accessed: Oct. 2021. [Online]. Available: <https://www.cenelec.eu/european-standardization/>
- [238] *ISO 55000:2014 Asset Management—Overview, Principles and Terminology*. Accessed: Oct. 2021. [Online]. Available: <https://www.iso.org/standard/55088.html>
- [239] *ISO 55001:2014 Asset Management—Management Systems—Requirements*. Accessed: Oct. 2021. [Online]. Available: <https://www.iso.org/standard/55089.html>
- [240] *ISO 55002:2018 Asset Management—Management Systems—Guidelines for the Application of ISO 55001*. Accessed: Oct. 2021. [Online]. Available: <https://www.iso.org/standard/70402.html>
- [241] *IEC 60300-1:2014 Dependability Management—Part 1: Guidance for Management and Application*. Accessed: Oct. 2021. [Online]. Available: <https://webstore.iec.ch/publication/1293>
- [242] *IEC 60706-2:2006 Maintainability of Equipment—Part 2: Maintainability Requirements and Studies During the Design and Development Phase*. Accessed: Oct. 2021. [Online]. Available: <https://webstore.iec.ch/publication/3013>
- [243] *IEC 62308:2006 Equipment Reliability—Reliability Assessment Methods*. Accessed: Oct. 2021. [Online]. Available: <https://webstore.iec.ch/publication/6799>
- [244] *ISO 18129:2015 Condition Monitoring and Diagnostics of Machines—Approaches for Performance Diagnosis*. Accessed: Oct. 2021. [Online]. Available: <https://www.iso.org/standard/61522.html>
- [245] *ANSI/NETA MTS-2019 Standard for Maintenance Testing Specifications for Electrical Power Equipment and Systems*. Accessed: Oct. 2021. [Online]. Available: <https://www.netaworld.org/standards/ansi-neta-mts#:~:text=ANSI%2FNETAMTS-2019,-StandardforMaintenance&text=The sespecificationsincorporatecomprehensivefield,powerdistribution equipmentandsystems>
- [246] *IEC 61709:2017 RLV Redline Version Electric Components—Reliability—Reference Conditions for Failure Rates and Stress Models for Conversion*. Accessed: Oct. 2021. [Online]. Available: <https://webstore.iec.ch/publication/59985>
- [247] *ISO 16079-1:2017 Condition Monitoring and Diagnostics of Wind Turbines—Part 1: General Guidelines*. Accessed: Oct. 2021. [Online]. Available: <https://www.iso.org/standard/55634.html>
- [248] *ISO 16079-2:2020 Condition Monitoring and Diagnostics of Wind Turbines—Part 2: Monitoring the Drivetrain*. Accessed: Oct. 2021. [Online]. Available: <https://www.iso.org/standard/67618.html>
- [249] *ISO 19283:2020 Condition Monitoring and Diagnostics of Machines—Hydroelectric Generating Units*. Accessed: Oct. 2021. [Online]. Available: <https://www.iso.org/standard/64262.html>
- [250] *492–1999—IEEE Guide for Operation and Maintenance of Hydro-Generators*. Accessed: Oct. 2021. [Online]. Available: <https://ieeexplore.ieee.org/document/749037>
- [251] *C57.93-2019—IEEE Guide for Installation and Maintenance of Liquid-Immersed Power Transformers*. Accessed: Oct. 2021. [Online]. Available: <https://ieeexplore.ieee.org/document/8713998>
- [252] *1808–2011—IEEE Guide for Collecting and Managing Transmission Line Inspection and Maintenance Data*. Accessed: Oct. 2021. [Online]. Available: <https://standards.ieee.org/standard/1808-2011.html>
- [253] *516–2021—IEEE Guide for Maintenance Methods on Energized Power Lines*. Accessed: Oct. 2021. [Online]. Available: <https://ieeexplore.ieee.org/document/9678146>
- [254] *Protection System, Automatic Reclosing, and Sudden Pressure Relaying Maintenance*. Accessed: Oct. 2021. [Online]. Available: <https://www.nerc.com/pa/Stand/ReliabilityStandards/PRC-005-6.pdf>
- [255] *IEC 61850:2022 SER Series: Communication Networks and Systems for Power Utility Automation—all Parts*. Accessed: Oct. 2021. [Online]. Available: <https://webstore.iec.ch/publication/6028>
- [256] *IEC 61968-4:2019 Application Integration at Electric Utilities—System Interfaces for Distribution Management—Part 4: Interfaces for Records and Asset Management*. Accessed: Nov. 2021. [Online]. Available: <https://webstore.iec.ch/publication/61452>
- [257] *IEC TR 62978:2017 HVDC Installations—Guidelines on Asset Management*. Accessed: Nov. 2021. [Online]. Available: <https://webstore.iec.ch/publication/27900>
- [258] *IEC TS 62775:2016 Application Guidelines—Technical and Financial Processes for Implementing Asset Management Systems*. Accessed: Nov. 2021. [Online]. Available: <https://webstore.iec.ch/publication/24782>
- [259] *SEGGC/M490/G_Smart Grid Set of Standards 22 Version 4.1*. Accessed: Nov. 2021. [Online]. Available: https://www.cenelec.eu/media/CEN-CENELEC/AreasOfWork/CEN-CENELEC_Topics/SmartGridsandMeters/SmartGrids/cgseg_sec_0042_report1.pdf
- [260] *NIST Framework and Roadmap for Smart Grid Interoperability Standards, Release 1.0*. Accessed: Nov. 2021. [Online]. Available: https://www.nist.gov/system/files/documents/public_affairs/releases/smartgrid_interoperability_final.pdf
- [261] *NIST Cybersecurity Framework*. Accessed: Nov. 2021. [Online]. Available: <https://www.nist.gov/cyberframework/framework>
- [262] M. Faheem, S. B. H. Shah, R. A. Butt, B. Raza, M. Anwar, M. W. Ashraf, M. A. Ngadi, and V. C. Gungor, "Smart grid communication and information technologies in the perspective of industry 4.0: Opportunities and challenges," *Comput. Sci. Rev.*, vol. 30, pp. 1–30, Nov. 2018.
- [263] P. Kundur, "Sustainable electric power systems in the 21st century: Requirements, challenges and the role of new technologies," in *Proc. IEEE Power Eng. Soc. Gen. Meeting*, Jun. 2004, pp. 2297–2298.
- [264] H. Shahinzadeh, J. Moradi, G. B. Gharehpetian, H. Nafisi, and M. Abedi, "Internet of Energy (IoE) in smart power systems," in *Proc. 5th Conf. Knowl. Based Eng. Innov. (KBEI)*, Feb. 2019, pp. 627–636.
- [265] R. Aracil, E. Pinto, and M. Ferre, "Robots for live-power lines: Maintenance and inspection tasks," *IFAC Proc. Volumes*, vol. 35, no. 1, pp. 13–18, 2002.
- [266] Z. Ren, A. S. Verma, Y. Li, J. J. E. Teuwen, and Z. Jiang, "Offshore wind turbine operations and maintenance: A state-of-the-art review," *Renew. Sustain. Energy Rev.*, vol. 144, Jul. 2021, Art. no. 110886.
- [267] A. Altamimi and D. Jayaweera, "Reliability of power systems with climate change impacts on hierarchical levels of PV systems," *Electr. Power Syst. Res.*, vol. 190, Jan. 2021, Art. no. 106830.
- [268] M. Z. Gargari, M. T. Hagh, and S. G. Zadeh, "Preventive maintenance scheduling of multi energy microgrid to enhance the resiliency of system," *Energy*, vol. 221, Apr. 2021, Art. no. 119782.

- [269] X. Ge, Q. Chen, Y. Fu, C. Y. Chung, and Y. Mi, "Optimization of maintenance scheduling for offshore wind turbines considering the wake effect of arbitrary wind direction," *Electr. Power Syst. Res.*, vol. 184, Jul. 2020, Art. no. 106298.
- [270] D. L. Donaldson, M. S. Alvarez-Alvarado, and D. Jayaweera, "Power system resiliency during wildfires under increasing penetration of electric vehicles," in *Proc. Int. Conf. Probabilistic Methods Appl. Power Syst. (PMAPS)*, Aug. 2020, pp. 1–6.
- [271] P. Dehghanian, B. Zhang, T. Dokic, and M. Kezunovic, "Predictive risk analytics for weather-resilient operation of electric power systems," *IEEE Trans. Sustain. Energy*, vol. 10, no. 1, pp. 3–15, Jan. 2019.
- [272] S. Skarvelis-Kazakos, M. Van Harte, M. Panteli, E. Ciapessoni, D. Cirio, A. Pitto, R. Moreno, C. Kumar, C. Mak, I. Dobson, C. Challen, M. Papic, and C. Rieger, "Resilience of electric utilities during the COVID-19 pandemic in the framework of the CIGRE definition of power system resilience," *Int. J. Electr. Power Energy Syst.*, vol. 136, Mar. 2022, Art. no. 107703.



MANUEL S. ALVAREZ-ALVARADO (Member, IEEE) was born in Guayaquil, Ecuador, in 1988. He received the degree in electrical power engineering and the master's degree (Hons.) in physics education from the Escuela Superior Politécnica del Litoral, Guayaquil, in 2011 and 2013, respectively, the M.Sc. degree (Hons.) in power and energy systems from the New Jersey Institute of Technology, Newark, NJ, USA, in 2015, the Ed.D. degree in physics from the National Polytechnic Institute of Mexico, and the Ph.D. degree in power systems from the University of Birmingham, Birmingham, U.K. He is currently a Professor with the Faculty of Electrical and Computer Engineering, Escuela Superior Politécnica del Litoral. His research interests include educational physics, quantum mechanics, renewable energy, and reliability of power systems.



DANIEL L. DONALDSON (Member, IEEE) received the B.S. degree in electrical and computer engineering, in 2012, and the master's degree in electrical engineering, in 2015. He is currently pursuing the Ph.D. degree with the University of Birmingham, Birmingham, U.K., with a focus on resilience of electric power systems. He worked at Southern California Edison (SCE) for seven years in a variety of roles, including work in distribution engineering, transmission planning, and demand and DER forecasting. He is a Licensed Professional Engineer in the State of California.



ANGEL A. RECALDE (Member, IEEE) was born in Guayaquil, Ecuador, in 1984. He received the bachelor's degree (Hons.) in electronic engineering and industrial automation from the Escuela Superior Politécnica del Litoral (ESPOL), Ecuador, in 2007, the M.Sc. degree in electrical engineering from the University of Queensland, Australia, in 2013, and the Ph.D. degree in electrical and electronic engineering from the University of Nottingham, U.K., in 2022. He is currently a Professor with the Faculty of Electrical and Computer Engineering, Escuela Superior Politécnica del Litoral (ESPOL). His research interest includes the design and optimization of distribution power systems.



HOLGUER H. NORIEGA (Member, IEEE) was born in Guayaquil, Ecuador, in 1991. He received the bachelor's degree (Hons.) in electronic engineering and industrial automation from the Escuela Superior Politécnica del Litoral (ESPOL), Ecuador, in 2014, and the M.Sc. degree in electrical engineering from the Politecnico di Milano, Italy, in 2020. He worked for the National DSO in SCADA system. He has performed several research activities meanwhile he worked as a Professor with the ESPOL. His research interests include renewable energy, data science in electrical systems, and reliability of power systems.



ZAFAR A. KHAN (Senior Member, IEEE) received the Ph.D. degree from the University of Birmingham. He received the postdoctoral training at Aston University and the University of Derby. He is currently an Assistant Professor at the Mirpur University of Science and Technology. His research interests include renewable energy integration, smart grids, power system reliability, load profiling, and load forecasting.



WASHINGTON VELASQUEZ (Senior Member, IEEE) received the master's degree in telematics services and network engineering and the Ph.D. degree in telematics system engineering from the Universidad Politécnica de Madrid, Madrid, Spain. He has authored/coauthored several articles in indexed journals and has led projects related to sensing and networking. He is currently a Professor with the Faculty of Electrical and Computer Engineering, Escuela Superior Politécnica del Litoral, Guayaquil, Ecuador. His research interests include telemetry, remote control, smart cities, and big data.



CARLOS D. RODRÍGUEZ-GALLEGOS (Senior Member, IEEE) received the B.Eng. degree (Hons.) in electrical engineering with specialization in electronics and industrial automation from the Escuela Superior Politécnica del Litoral, Guayaquil, Ecuador, in 2011, the dual M.Sc. degree in energy science and technology from the University of Ulm, Ulm, Germany, and the Fraunhofer ISE, Freiburg, Germany, in 2014, and the Ph.D. degree from the Department of Electrical and Computer Engineering, National University of Singapore (NUS), Singapore. He is currently a Research Fellow with the Solar Energy Research Institute of Singapore, NUS. His research interests include the fields of photovoltaic cells, modules, and systems and optimization design, and power electronics.

...