

# Smart maintenance model for operational planning of static synchronous compensators

Alvarez Alvarado, Manuel; Jayaweera, Dilan

DOI:

[10.1109/PTC.2019.8810830](https://doi.org/10.1109/PTC.2019.8810830)

License:

Other (please specify with Rights Statement)

*Document Version*

Peer reviewed version

*Citation for published version (Harvard):*

Alvarez Alvarado, M & Jayaweera, D 2019, Smart maintenance model for operational planning of static synchronous compensators. in *2019 IEEE Milano Powertech.*, 8810830, IEEE Milan PowerTech, Institute of Electrical and Electronics Engineers (IEEE), pp. 1-6, IEEE PowerTech 2019, 13th, Milano, Italy, 23/06/19. <https://doi.org/10.1109/PTC.2019.8810830>

[Link to publication on Research at Birmingham portal](#)

## **Publisher Rights Statement:**

© 20xx IEEE. Personal use of this material is permitted. Permission from IEEE must be obtained for all other uses, in any current or future media, including reprinting/republishing this material for advertising or promotional purposes, creating new collective works, for resale or redistribution to servers or lists, or reuse of any copyrighted component of this work in other works.

M. S. Alvarez-Alvarado and D. Jayaweera, "Smart Maintenance Model for Operational Planning of Static Synchronous Compensators," 2019 IEEE Milan PowerTech, Milan, Italy, 2019, pp. 1-6.  
doi: 10.1109/PTC.2019.8810830

## **General rights**

Unless a licence is specified above, all rights (including copyright and moral rights) in this document are retained by the authors and/or the copyright holders. The express permission of the copyright holder must be obtained for any use of this material other than for purposes permitted by law.

- Users may freely distribute the URL that is used to identify this publication.
- Users may download and/or print one copy of the publication from the University of Birmingham research portal for the purpose of private study or non-commercial research.
- User may use extracts from the document in line with the concept of 'fair dealing' under the Copyright, Designs and Patents Act 1988 (?)
- Users may not further distribute the material nor use it for the purposes of commercial gain.

Where a licence is displayed above, please note the terms and conditions of the licence govern your use of this document.

When citing, please reference the published version.

## **Take down policy**

While the University of Birmingham exercises care and attention in making items available there are rare occasions when an item has been uploaded in error or has been deemed to be commercially or otherwise sensitive.

If you believe that this is the case for this document, please contact [UBIRA@lists.bham.ac.uk](mailto:UBIRA@lists.bham.ac.uk) providing details and we will remove access to the work immediately and investigate.

# Smart Maintenance Model for Operational Planning of Static Synchronous Compensators

Manuel S. Alvarez-Alvarado and Dilan Jayaweera.  
Department of Electronic, Electrical and Systems Engineering  
University of Birmingham  
Birmingham, United Kingdom  
Email: {msa583, d.jayaweera}@bham.ac.uk

**Abstract**— This paper proposes an innovative smart maintenance (SM) model for scheduling proactive preventive maintenance of static synchronous compensators (STATCOMs). The approach is primarily useful for optimal operational planning of STATCOMs to maximize net benefit that comes from the difference between the power losses reduction savings and the cost of STATCOM's acquisition and maintenance. SM model incorporates: 1. Markov chains to describe STATCOM reliability with aging features; and 2. Type I restoration factor to describe the impact of maintenance over component's virtual age. The optimization problem is solved using the Accelerated Quantum Particle Swarm Optimization (AQPSO) which involves three stages. The first stage determines the optimum number, size, and placement of the STATCOMs. The second stage set the effective maintenance plan. The last stage governs the best operation of the STATCOMs. The results show the efficacy of the proposed model, opening a new pathway to future applications in smart grids.

**Keywords**—*accelerated quantum particle swarm optimization, operation, planning, power losses, reliability, smart miantenance, static synchronous compensator*

## I. INTRODUCTION

In a power system, the electrical power losses due to the Joule effect are inevitable. Nevertheless, these can be reduced by injecting reactive power into the network locally. Although literature presents the employment of capacitors [1] as a simple and popular contingency measure, the electric utilities are using static synchronous compensators (STATCOMs) instead [2]. This is attributed to its dynamic and fast response at the need of reactive power compensation.

There are several studies that show the efficacy of STATCOMs. For instance, [3] presents the effect of optimal allocation of multiple STATCOM in a radial distribution system; [4] offers a plausible operation of STATCOM applied to the electrical system of the Republic of Tajikistan is given; [5] presents a case study given by the National Grid (sole transmission company in England and Wales) in which the STATCOM planning is required to maintain a high-quality standard, which includes the minimization of power losses. Even though these studies present different methodologies to obtain the optimum planning (sizing and placement) and operation (reactive compensation dispatch strategy) for STATCOM based on power losses reduction, the impact of maintenance on it is not clearly given.

It is not possible to keep a continuous operation of the power system components since they are exposed to aging effect that eventually leads to a failure. Nonetheless, the occurrence of failures can be reduced by performing a maintenance, which can be corrective (CM) or preventive (PM). Once a failure occurs, the CM is employed to restore the component to an operative condition, while the PM is used as a control measure to prevent failures [6]. The greater number of PM is performed, the more reliable the component becomes, but there must be a balance between the cost and the benefit of each PM executed, since at some point the cost could be higher than the benefit. For this reason, in the last few years, the concept of maintenance has evolved to a new level called Smart Maintenance (SM), which includes smart-inspections [7], smart-devices [8] and smart-services [9], giving a scheduled and proactive maintenance. There is no well-established analytical method that allows to describe SM in mathematical terms.

This paper presents a comprehensive methodology that optimize the number, size, placement, dispatch strategy for reactive compensation and PM maintenance plan for STATCOMs. Their reliability model is obtained by Markov chains [10], and the effect of maintenance is quantified using the type I restoration factor (RFI) [11]. The objective is to maximize the net benefit that comes from the difference between the power losses reduction savings and the cost of STATCOM's acquisition and maintenance. The optimization problem is solved using the Accelerated Quantum Particle Swarm Optimization (AQPSO), which is mainly divided into three stages. The first stage focuses on the optimum planning of STATCOMs; the second stage is employed to set a plausible PM schedule; and the third stage determines the STATCOMs optimum operation. The rest of the paper is structured as follows: section II presents the STATCOM's electrical and reliability models; section III describes the SM mathematical model; in section IV, the optimization problem is presented; section V presents the proposed algorithm; section VI shows a case study; section VII brings the results and discussion; finally, section VII concludes findings.

## II. STATIC SYNCHRONOUS COMPENSATORS

The STATCOM can interact with any distributed generation, nonetheless, this research focus on its application for reactive compensation. The electrical and reliability model is as presented below.

### A. Electrical Model

The STATCOM incorporates high power IGBTs, reactors and capacitors that allows to perform the reactive compensation [12]. Its current injection mathematical model in terms of is the system voltage  $\bar{U}_M$ , STATCOM's susceptance  $B_S$  and phase angle operation  $\alpha$ , is as follows [13]:

$$\bar{I}_S = j\bar{U}_S B_C(\alpha) \Rightarrow Q_S \quad (1)$$

The STATCOM primarily depends on the operation phase angle, which is controlled by using a reference voltage  $U_S$ , leading to a reactive power dispatched  $Q_S$ . This control limits the optimum operation for the maximum net benefit. For instance, in a traditional control system, the reference voltage is usually 1.0 p.u. and based on this value, the STATCOM injects a reactive current in order to keep the bus voltage in the desired value. Nevertheless, the injected reactive current may not lead to a maximum net benefit and a new voltage reference is needed as shown in Fig. 1. Thus, an optimal scheduling for STATCOM is needed. This is obtained by the employment of a novel metaheuristic technique which will be described in Section III.

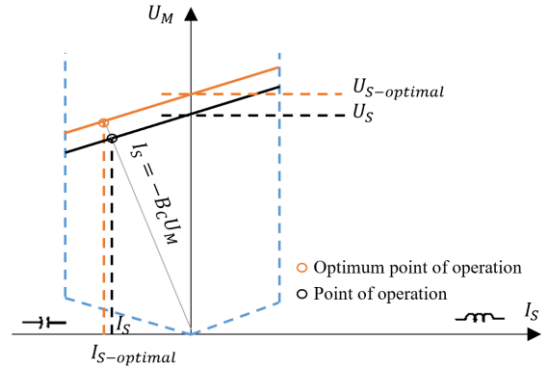

Fig. 1 STATCOM voltage and current characteristic

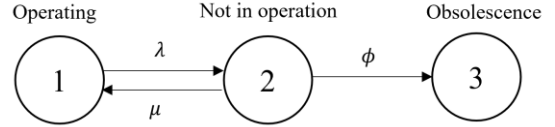

Fig. 2 STATCOM Markov chain model

### B. Reliability Model

The availability is a measure of component's reliability, and it can be obtained by using the Markov chain [14]. This is a schematic representation of all possible states, which are connected between them by the transition rates. For instance, Fig. 2 presents the Markov chain for a STATCOM, with three possible states. The state "1" is named "Operating" and in this state the component is working properly; the state "2" is labelled as "Not in operation" and it refers to the occurrence of failure; the state "3" is called "Obsolescence" and it represents the end of component's lifetime. In addition, the variables  $\lambda$ ,  $\mu$  and  $\phi$  are defined as the failure, repair and degradation rate, respectively.

The solution to the model is given by the probability function of being in each state. For that purpose, the stochastic matrix  $H$  is required. This matrix is the infinitesimal generator chain, in which the diagonal terms  $h_{jj}$  are the negative of the sum of all states that goes out of the state  $j$ . On the other hand, the terms out of the diagonal  $h_{jk}$  are the transition state from  $j$  to  $k$  state [14]. Therefore, the stochastic matrix that represents the model in Fig. 2 is as presented in (2).

$$H = \begin{bmatrix} -\lambda & \lambda & 0 \\ \mu & -\mu - \phi & \phi \\ 0 & 0 & 0 \end{bmatrix} \quad (2)$$

Then, the probabilities of being in each state is as follows:

$$\begin{bmatrix} P_1(t) \\ P_2(t) \\ P_3(t) \end{bmatrix} = \begin{bmatrix} c_1 v_{11} e^{\lambda t} + c_2 v_{12} e^{\lambda t} + c_3 v_{13} e^{\lambda t} \\ c_1 v_{21} e^{\lambda t} + c_2 v_{22} e^{\lambda t} + c_3 v_{23} e^{\lambda t} \\ c_1 v_{31} e^{\lambda t} + c_2 v_{32} e^{\lambda t} + c_3 v_{33} e^{\lambda t} \end{bmatrix} \quad (3)$$

where  $\lambda$  is the eigenvalues of  $H^T$ ,  $v_{ij}$  is the element of the matrix formed by the eigenvectors of  $H^T$  and  $c$  is a constant given by the initial state;  $T$  indicates the transpose of the matrix.

Since  $P_1$  is the only state in which the component is working properly, then the availability and unavailability of the STATCOM are as given in (4) and (5), respectively.

$$A(t) = P_1(t) \quad (4)$$

$$U(t) = P_2(t) + P_3(t) \quad (5)$$

### C. Degradation Rate

The reliability model requires to know the degradation of the component. To get it, let's start by defining the term "absorbing state". This is described as the state in which once it is reached, there is no possibility to go to any other state. The particularity of this state is that it presents a mean time to absorption defined as [15]:

$$T = \frac{\lambda + \phi + \mu}{\lambda \phi} \quad (6)$$

In this approach, the mean time to absorption is the useful lifetime of the component, which is given by the manufacturer. Consequently, from (6):

$$\phi = \frac{\lambda + \mu}{T\lambda - 1} \quad (7)$$

## III. SMART MAINTENANCE MATHEMATICAL APPROACH

The SM is based on two main concepts, which are described in this section.

### A. Type I Improvement Factor

Maintenance action causes a rejuvenation over component's virtual age  $V$ . The type I restoration factor (RFI) comes from the theory exposed by Kijima [11], in which the repairs can fix only the wear-out and damage incurred during the period of operation since the last repair. The effect of maintenance over the virtual age of a component is by an amount proportional to the time elapsed from the  $n - 1$ th failure to the  $n$ th failure. Then, the RFI can be described mathematically as [11]:

$$V_n = \begin{cases} V_{n-1} + q_{CM} X_n, & \text{if CM is performed} \\ V_{n-1} + q_{PM} X_n, & \text{if PM is performed} \end{cases} \quad (8)$$

where  $X$  is the time between failures and  $q$  is the restoration factor such that  $0 \leq q \leq 1$ .

Since the virtual age change when maintenance is executed, the degradation will be reduced, therefore, the occurrence of failures (unavailability) will be reduced.

### B. Quantum Particle Swarm Optimization

The SM scheme requires an optimization technique and in this paper the Quantum Particle Swarm Optimization (QPSO) is employed. The QPSO is an evolutionary computation technique that unlike classical PSO, it does not employ the concept of velocity to get the optimal solution. Instead, it associates a wave function to each particle, which represents the compress information about the particle that depends on the potential field that lies in. The scenario of the particle is a quantum well. Each particle has a memory of its own best position called personal best  $D_i(k)$ . However, this is not the only particle since there is a total of  $SS$  particles, hence there must be a solution of the whole swarm, called global best  $g(k)$ . The particle  $i$  at search step  $k$  initially is in the position  $x_i(k)$  and it will move to a position defined by the local attractor  $p_i(k)$ . Based on a trajectory analysis the authors in [16] proposed a local attractor following the coordinates:

$$\begin{aligned} p_i(k) &= \varphi(k)D_i(k) + (1-\varphi(k))g(k) \\ \varphi(k) &= d_1r_1 / (d_1r_1 + d_2r_2) \end{aligned} \quad (9)$$

where  $r_1$  and  $r_2$  are random numbers uniformly distributed between  $[0,1]$ ,  $d_1$  and  $d_2$  are the acceleration coefficients, such that  $0 \leq d_1, d_2 \leq 2$ .

The local attractor is relevant to define since the initial position of the particle mainly depend on it. To understand in a better way the scenario of the particle, a comprehensive representation of the model is given in Fig. 3, from which:

$$\Delta x_i = p_i(k) \pm x_i(k+1) \quad (10)$$

Then, the updated position of the particle is defined by [17]:

$$x_i(k+1) = p_i(k) \pm \alpha \left| x_i(k) - \frac{1}{SS} \sum_{i=1}^{SS} D_i(k) \right| \ln\left(\frac{1}{u}\right) \quad (11)$$

The position of the particle is in a multi-state (like the Schrödinger cat) and it is not possible to determine the updated position until an observation take place. Given that the position of the particle is  $x_i(k)$ , at step  $k+1$ , the particle may appear in the zone  $(-x_i(k+1), +x_i(k+1))$ . The probability for each state is 0.5 determined by the observation  $obs = rand(0,1)$  [17].

The traditional QPSO employs one observer to define the next position of the particle. Nonetheless, to accelerate the convergence and enhance the accuracy of the results, this paper proposes to increase the number of observers to an odd natural number  $y$ , which is greater than one, in such a way that the set of observers is as shown in (12).

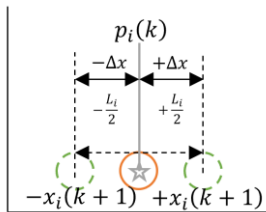

Fig. 3 A particle in a quantum well

$$\begin{aligned} A \cup B &= \{obs_1, obs_2, \dots, obs_y\} \\ A &= \{\text{all } obs \geq 0.5\}; B = \{\text{all } obs < 0.5\} \end{aligned} \quad (12)$$

The number of elements in a set is known as cardinality and its operator is defined as ‘card’, then the observer is chosen based on the following formulation:

$$\begin{aligned} \text{if } \text{card}(A) > \text{card}(B) &\Rightarrow Obs \geq 0.5 \\ \text{if } \text{card}(A) < \text{card}(B) &\Rightarrow Obs < 0.5 \end{aligned} \quad (13)$$

Then (11) can be written as:

$$x_i(k+1) = \begin{cases} p_i(k) + \alpha \left| x_i(k) - \frac{1}{SS} \sum_{i=1}^{SS} D_i(k) \right| \ln\left(\frac{1}{u}\right), & \text{if } Obs \geq 0.5 \\ p_i(k) - \alpha \left| x_i(k) - \frac{1}{SS} \sum_{i=1}^{SS} D_i(k) \right| \ln\left(\frac{1}{u}\right), & \text{if } Obs < 0.5 \end{cases} \quad (14)$$

A graphical representation of the updated position of the particle is as shown in Fig. 4.

### IV. PROBLEM FORMULATION

The objective is to maximize the net benefit obtained from the difference between the savings due to reduction of losses and the cost of maintenance. The STATCOM injects reactive power which causes a decrement in the current magnitude that flows through the conductor  $p$ . The result is a reduction in the electrical losses given the following relationship:

$$\Delta L_p = (I_p^2 - I_p'^2)R_p \quad (15)$$

where  $I$  is the current that normally flows through the conductor,  $I'$  is the current obtained considering the installation of STATCOMs and  $R$  is the conductor’s resistance. The relevance of the electrical losses is that they represent economic benefit defined by the following equation:

$$B = w_L \sum_{j=1}^{NC} \Delta L_j \quad (16)$$

where  $NC$  is the total number of conductors in the power system and  $w_L$  is the price per unit energy given in [£/kwh].

On the other hand, the acquisition and installation of STATCOMs imply a cost which can be quantified as follows:

$$C_S = w_S \sum_{j=1}^{NQ} Q_{S_j} \quad (17)$$

where  $Q_S$  represent the size of the STATCOM given in [kVAr],  $NQ$  is the total number of STATCOMs installed into the power system and  $w_S$  is the price per unit energy given in [£/kVAr].

Another cost to consider is the one that comes from the execution of maintenance. In case of CM action, the cost is related with the repair or substitution of the failed part in the component, while for PM action, the cost is related with the material needed to perform inspection and prevent any failure.

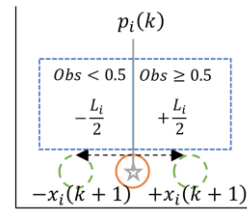

Fig. 4 Updated position of the particle using AQPSO

Hence, the total maintenance cost can be expressed as [18]:

$$C_m = \sum_{e=1}^{NC} (Cost_{PM,e} M_{PM,e} + Cost_{CM,e} M_{CM,e}) \quad (18)$$

where  $NC$  is total number of components in the system,  $Cost_{PM,e}$  is the price of performing one PM on component  $e^{\text{th}}$ ,  $Cost_{CM,e}$  is the price of performing one CM on component  $e^{\text{th}}$ ,  $M_{PM,e}$  is the total number of PM performed on component  $e^{\text{th}}$  during time interval  $(0, T_s]$  and  $M_{CM,e}$  is the total number of PM performed on component  $e^{\text{th}}$  during time interval  $(0, T_M]$ .

Concerning the operation of the STATCOM, this is time dependant since the load profile varies on time. Therefore, an hourly time-slotted system with slot index  $t$  is considered for the problem formulation. Later, the net benefit becomes as follows:

$$NB(t) = S_L(t) - C_S - C_M \quad (19)$$

At this point, the optimization problem can be defined as:

$$\text{maximize } (S_{\text{Total}}(t)) \quad (20)$$

Subject to:

$$P_{\text{grid}}(t) = \sum_{j=1}^{NL} P_{\text{load } j}(t) + \sum_{j=1}^{NC} P_{\text{losses } j}(t), \{j, t\} \in \mathbb{N} \quad (21)$$

$$Q_{\text{grid}}(t) = \sum_{j=1}^{NL} Q_{\text{load } j}(t) - \sum_{j=1}^{NS} Q_{S_j}(t) + \sum_{j=1}^{NC} Q_{\text{losses } j}(t), \{j, t\} \in \mathbb{N} \quad (22)$$

$$Q_{\min(\text{SVC } j)} \leq Q_{S_j}(t) \leq Q_{\max(\text{S } j)}, \{j, t\} \in \mathbb{N} \quad (23)$$

$$V_{\min(\text{bus } j)} \leq |V_{\text{bus } j}(t)| \leq V_{\max(\text{bus } j)}, \{j, t\} \in \mathbb{N} \quad (24)$$

$$M_{CM,e} \in \mathbb{N}, M_{PM,e} \in \mathbb{N}, e \in \mathbb{N} \quad (25)$$

$$0 \leq NS \leq NS_{\text{available}} \quad (26)$$

The restrictions (21) and (22) establish that the power (real or reactive) given by the generation must satisfy the load and electrical power losses. The reactive power produced by an installed STATCOM is limited by (23), since it has a minimum and maximum reactive power that can supply. The restriction given in (24) assures a voltage regulation for each bus. The restriction (25) establishes that the number CM, PM and components must be positive integers. Finally, (26) is used to control the number of STATCOM installed, which cannot be greater than the number of busses of the power system.

## V. PROPOSED ALGORITHM FOR OPTIMUM PLANNING AND OPERATION OF STATIC VAR COMPENSATOR

The employed optimization technique is the AQPSO, which is divided into three stages. The first stage is labeled as  $AQPSO_{SP}$ , and it is used to estimate the optimal placement and sizing for the STATCOMs; the second stage is named  $AQPSO_{SM}$  and it brings the effective maintenance plan for each STATCOM installed; the last stage is called  $AQPSO_{OP}$ , that allows to get their optimal operation strategy.

The algorithm starts by defining the available STATCOM in stock. Next, the maximum number of iterations for  $AQPSO_{SP}$  is defined. Then, an initial population of particles is randomly generated. Each of these is a possible solution for the objective function, therefore, each of these become a set of STATCOM with a given size and placement.

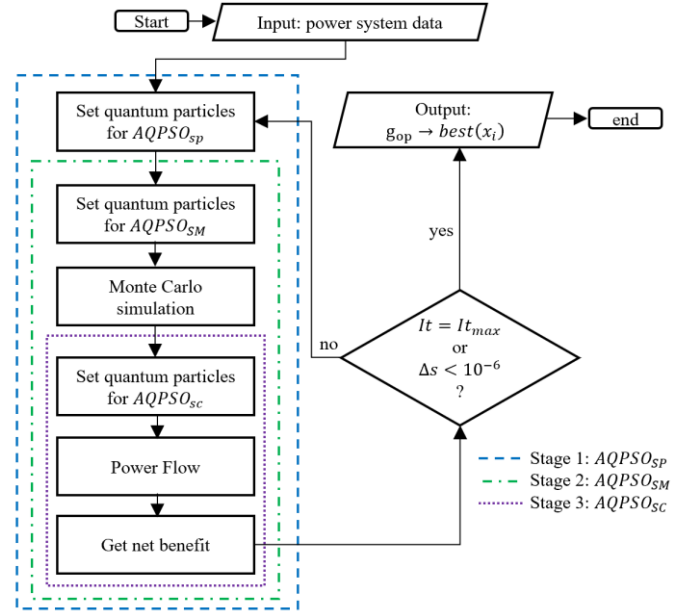

Fig. 5 Flow chart for SM Model for Effective Planning and Operation

Subsequently, the  $AQPSO_{SM}$  takes place in which the particles decided the best month to perform the maintenance during the time assigned. In this stage, a Monte Carlo simulation is employed to estimate the state of the STATCOMs. Following the procedure, to evaluate the objective function, a new set of particles (here starts  $AQPSO_{OP}$ ) is defined. These new particles take a value of operation between the maximum and minimum reactive power given defined by each STATCOM. This is followed by the execution of a power flow that uses Newton Raphson technique. Then, the net benefit for each particle is obtained using (19). The particle with the best solution becomes the global best. Then, each particle starts moving (change its operation point) based on the global best by using (14). If there is a particle that achieves an improved total saving, the global best is updated and the particle with this solution becomes the new global best. This process is repeated until the maximum number of iterations ( $It_{max}$ ) has been reached or if the values of the net benefit have a difference ( $\Delta s$ ) of  $10^{-6}$  between the current and previous iteration, assuring a convergence in the solution. A summarized flowchart of the proposed algorithm is presented in Fig. 5.

## VI. CASE STUDY

The study incorporates the IEEE 24 bus reliability test system [19]. The network is a power transmission system that consists of 24 buses, which are connected by 38 lines and transformers, and it presents a peak load of 2850 MW and 580 MVar. To simplify the analysis, the assumptions are made as follows: 1. load balanced conditions; 2. constants values related to price are  $w_L = 0.02$  [ $\text{£}/kWh$ ];  $w_S = 4 \times 10^4$  [ $\text{£}/MVar$ ]; 3. weekly load demand profile is kept constant for the whole year and is as shown in Fig. 6; 4. the restoration factor for PM and CM is 0.4 and 0.6, respectively; 5. Bus voltage must meet IEEE Standard 1860-2014 [20] that is  $0.95 p.u. \leq V_{bus} \leq 1.05 p.u.$ ; 6. available STATCOM in stock are shown in Table I.

Table I. Available 3-phase STATCOM

STATCOM:	A	B	C	D	E
Size [MVar]:	10	20	50	100	120
$T$ [years]:	17	20	25	30	35
$\lambda$ [failure/year]:	1.390	1.107	1.060	0.907	0.706
$\mu$ [repair/year]:	302	288	258	210	198
PM cost [k£]:	10	20	50	100	120
CM cost [k£]:	32	64	160	320	384

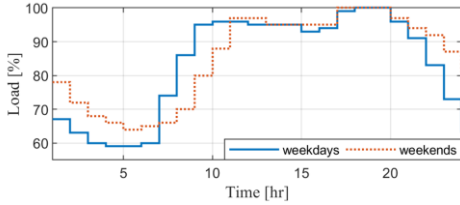

Fig. 6 Load profile

## VII. RESULTS AND DISCUSSION

### A. STATCOM Optimal Planing: Placement and Sizing

There are several possible combinations in which the available STATCOMs can be placed in the power system. Nevertheless, among them, there is a combination that brings the maximum reduction of power losses and hence the maximum net benefit results. This is presented in Fig. 7.

### B. STATCOM Optimal PM Schedule

By using the algorithm described in Section V, the PM schedule that maximizes the net benefit is obtained. As a result, Fig. 8 shows the effective PM scheduling applied to each STATCOM. To understand Fig. 8, a symbol is defined for every STATCOM. Then, the time when the action takes place is given by the interception point formed from figure axis. The month is determined by the x-axis while the year is defined by its y-axis. For instance, the first PM to execute is on the STATCOM installed in node 3 (S-n3  $\circ$ ) in June of the first year.

The SM affects the availability of every installed device, as shown in Fig. 9. To show efficacy of SM over any other maintenance plan, three different scenarios are presented: 1. No PM performed (NPM); 2. yearly periodic PM (PPM); 3. smart-maintenance (SM). This is relevant since availability has a strong impact over the net benefit as will be discussed below.

### C. STATCOM Optimal Operation: Dispatch Strategy

The operation for each STATCOM during weekdays and weekends is shown in Fig. 10. In addition, to show that bus voltages limits follow the IEEE Standard 1860-2014 [20] ( $0.95 p.u. \leq V_{bus} \leq 1.05 p.u.$ ), Fig. 11 is presented.

### D. Maximum Net benefit

Due to the high investment needed for the implementation of the compensators, it is notable that initially, the cost will be higher than the benefit. To recover the investment and start getting revenue, the analysis considers a time study of 10 years. The total yearly power losses reduction for every scenario stated in last section is different. This is attributed to the manner in which aging is faced, resulting in the maximum net benefit for the SM model as presented in Table II.

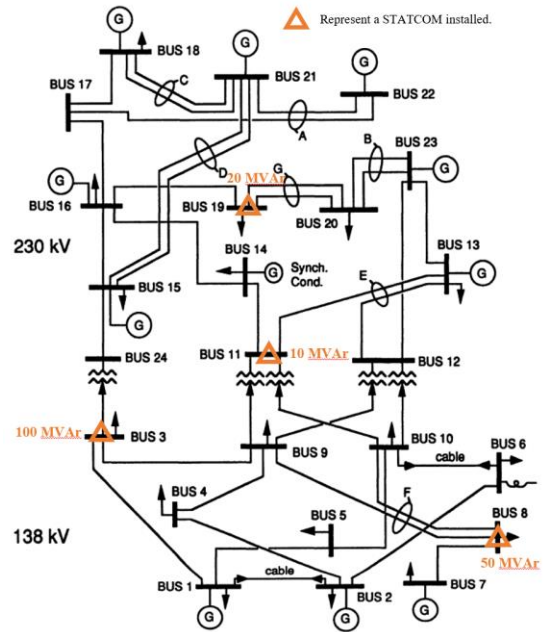

Fig. 7 Optimal placement and sizing for STATCOM

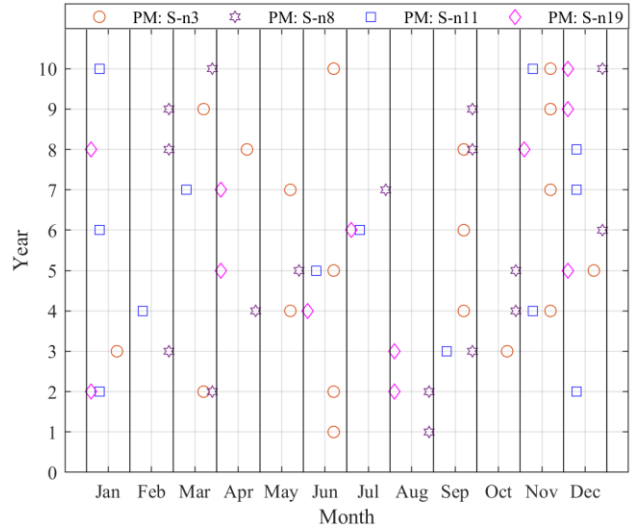

Fig. 8 Effective PM plan for each STATCOM installed

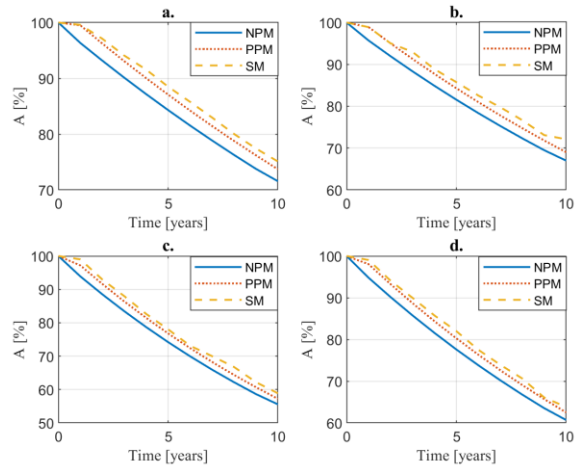

Fig. 9 Availability of STATCOM installed in node: a) 3; b) 8; c) 11; d) 19

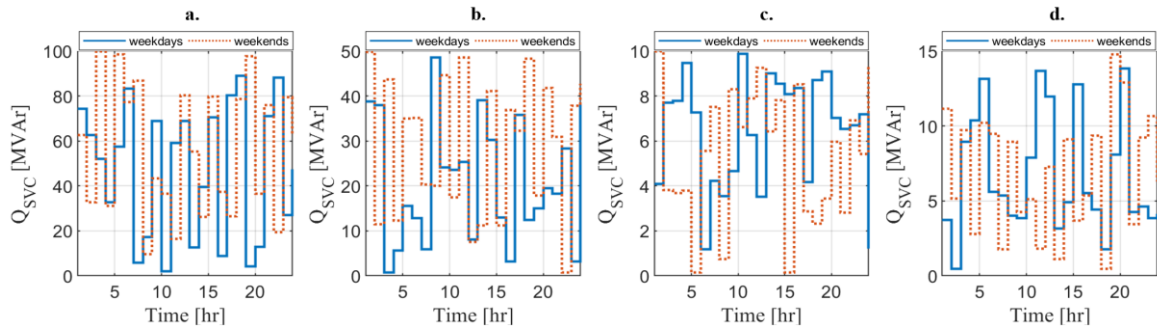

Fig. 10 Optimal dispatch strategy for STATCOM installed at node: a) 3; b) 8.; c) 11; d) 19

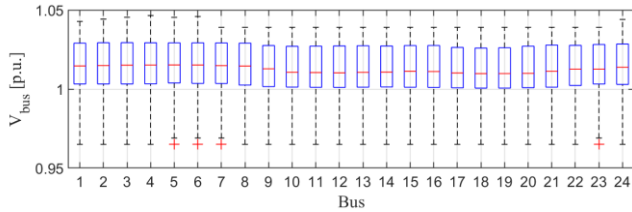

Fig. 11 Voltage regulation with STATCOM installed using SM scheme

Table II. Net Benefit after 10 years

Scenario:	No-PM	PPM	SM
Net Benefit [£]:	$2.9636 \times 10^5$	$4.9837 \times 10^5$	$5.1137 \times 10^5$

### VIII. CONCLUSION

A novel analytical method that describes SM in mathematical terms is presented. The approach is used to obtain the optimal sizing, placement, dispatch strategy and PM planning of STATCOMs. The results depict that the installation of STATCOM into the power system keep the voltages within the desired ranges as established in the IEEE Standard 1860-2014. Even though the acquisition and maintenance cost of the STATCOM is relatively high, the former in the long-term tends to be economical.

The PM plan obtained from the SM demonstrates to be superior to the yearly periodic PM plan. This is because SM takes better advantage of investment resources, and it looks for the optimal number and time to execute PM. This ensures a much more reliable operation for the component, leading to a greater net benefit.

Although this paper employs the SM scheme for STATCOM, the model can be used for other devices, opening to a range of possibilities for future research.

### REFERENCES

- [1] B. R. Pereira, G. R. M. da Costa, J. Contreras, and J. R. S. Mantovani, "Optimal Distributed Generation and Reactive Power Allocation in Electrical Distribution Systems," *IEEE Trans. Sustain. Energy*, vol. 7, no. 3, pp. 975–984, 2016.
- [2] H. Bilodeau *et al.*, "Making Old New Again: HVdc and FACTS in the Northeastern United States and Canada," *IEEE Power Energy Mag.*, vol. 14, no. 2, pp. 42–56, 2016.
- [3] A. R. Gupta, "Effect of optimal allocation of multiple DG and D-STATCOM in radial distribution system for minimizing losses and THD," in *2017 7th International Symposium on Embedded Computing and System Design (ISED)*, 2017, pp. 1–5.
- [4] V. Z. Manusov, A. K. Kirgizov, and J. S. Ahyoev, "The effective use of STATCOM in the electrical system of the Republic of Tajikistan to reduce the losses of active power in the electric network," in *2016 13th International Scientific-Technical Conference on Actual Problems of Electronics Instrument Engineering (APEIE)*, 2016, vol. 03, pp. 60–63.
- [5] M. G. G. Titus, "Reactive power compensation using STATCOM for single phase distribution system," in *2015 International Conference on Circuits, Power and Computing Technologies [ICCPCT-2015]*, 2015.
- [6] "IEEE Guide for Maintenance, Operation, and Safety of Industrial and Commercial Power Systems (Yellow Book)," *IEEE Std 902-1998*, pp. 1–160, 1998.
- [7] Z. Ding, T. Wu, and H. Shen, "Based on RFID and temperature tag smart inspection and maintenance technology for distribution power network," in *Electricity Distribution (CICED), 2016 China International Conference on*, 2016, pp. 1–5.
- [8] M. Maritsch, C. Lesjak, and A. Aldrian, "Enabling smart maintenance services: Broker-based equipment status data acquisition and backend workflows," in *Industrial Informatics (INDIN), 2016 IEEE 14th International Conference on*, 2016, pp. 699–705.
- [9] J. D. Moseley, W. M. Grady, and S. Santoso, "New approaches for smart device integration and maintenance of power system models utilizing a unified data schema," in *Innovative Smart Grid Technologies (ISGT), 2013 IEEE PES*, 2013, pp. 1–6.
- [10] M. S. Alvarez-Alvarado and D. Jayaweera, "Reliability model for a Static Var Compensator," in *2017 IEEE Second Ecuador Technical Chapters Meeting (ETCM)*, 2017, pp. 1–6.
- [11] A. Nasr, S. Gasmir, and M. Sayadi, "Estimation of the parameters for a complex repairable system with preventive and corrective maintenance," in *Electrical Engineering and Software Applications (ICEESA), 2013 International Conference on*, 2013, pp. 1–6.
- [12] N. G. Hingorani, "FACTS technology-state of the art, current challenges and the future prospects," in *IEEE Power Engineering Society General Meeting*, 2007, vol. 2.
- [13] E. Acha, C. R. Fuerte-Esquivel, H. Ambriz-Perez, and C. Angeles-Camacho, *FACTS: modelling and simulation in power networks*. John Wiley & Sons, 2004.
- [14] M. S. Alvarez-Alvarado and D. Jayaweera, "Aging Reliability Model for Generation Adequacy," in *2018 IEEE International Conference on Probabilistic Methods Applied to Power Systems (PMAPS)*, 2018, pp. 1–6.
- [15] M. S. Alvarez-Alvarado and D. Jayaweera, "Bathtub curve as a Markovian process to describe the reliability of repairable components," *IET Gener. Transm. Distrib.*, vol. 12, no. 21, pp. 5683–5689, 2018.
- [16] M. Clerc and J. Kennedy, "The particle swarm-explosion, stability, and convergence in a multidimensional complex space," *IEEE Trans. Evol. Comput.*, vol. 6, no. 1, pp. 58–73, 2002.
- [17] M. S. Alvarez-Alvarado and D. Jayaweera, "A New Approach for Reliability Assessment of a Static Var Compensator Integrated Smart Grid," in *2018 IEEE International Conference on Probabilistic Methods Applied to Power Systems (PMAPS)*, 2018, pp. 1–7.
- [18] A. Moradkhani, M. R. Haghifam, and S. M. Abedi, "Risk-based maintenance scheduling in the presence of reward penalty scheme," *Electr. Power Syst. Res.*, vol. 121, pp. 126–133, 2015.
- [19] C. Grigg *et al.*, "The IEEE reliability test system-1996. A report prepared by the reliability test system task force of the application of probability methods subcommittee," *IEEE Trans. power Syst.*, vol. 14, no. 3, pp. 1010–1020, 1999.
- [20] M. Shicong, G. Jianbo, H. Qing, Z. Jian, D. Mian, and Y. Zhao, "Guide for voltage regulation and reactive power compensation at 1000kV AC and above with IEEE P1860 standard," in *Power System Technology (POWERCON), 2014 International Conference on*, 2014, pp. 2092–2097.